

SHIMADZU

PRODUCT DATA

Radiographic
Mobile X-ray
System

MobileArt Evolution



GENERAL

The MobileArt Evolution is a general purpose mobile X-ray system, which can be freely moved throughout a hospital to directly obtain X-ray images of various areas of the body.

FEATURES

- | | | |
|---|--|--|
| <p>(1) Smooth and Quiet Movement
Power-assist technology allows moving the unit easily and quietly.</p> <p>(2) Compact Design
Excellent forward visibility allows freely moving through even tight spaces.</p> <p>(3) Easy Positioning
The system can be freely and quickly maneuvered into position using Inch-Mover buttons to move the main body and swiveling the column to move the X-ray tube.</p> <p>(4) Standard Anatomical Programs
Anatomical programs (APR) are installed as standard, to allow setting radiography parameters easily.</p> <p>(5) Cordless System
The built-in battery enables obtaining X-ray images without plugging in the unit.</p> <p>(6) Status Indicator Light
The status indicator light illuminates or blinks in response to X-ray exposure or system abnormalities. This allows a visual confirmation of system status.</p> <p>(7) FPD upgradeable (32 kW type only)</p> | <p>(3) Adjustment of tube voltage
32 kW type: 40 to 133 kV in increment of 1 kV
12.5 kW type: 40 to 125 kV in increment of 1 kV</p> <p>(4) Setting of mAs
0.32, 0.36, 0.40, 0.45, 0.50, 0.56, 0.63, 0.71, 0.80, 0.90, 1.0, 1.1, 1.2, 1.4, 1.6, 1.8, 2.0, 2.2, 2.5, 2.8, 3.2, 3.6, 4.0, 4.5, 5.0, 5.6, 6.3, 7.1, 8.0, 9.0, 10, 11, 12, 14, 16, 18, 20, 22, 25, 28, 32, 36, 40, 45, 50, 56, 63, 71, 80, 90, 100, 110, 125, 140, 160, 180, 200, 220, 250, 280, 320 mAs</p> <p>(5) Maximum mAs for each kV</p> <p>32 kW type:</p> <p>a) In case of General radiography</p> <p>Large focus
40 to 90 kV: 320 mAs
91 to 100 kV: 280 mAs
101 to 110 kV: 250 mAs
111 to 120 kV: 220 mAs
121 to 133 kV: 200 mAs</p> <p>Small focus
40 to 90 kV: 320 mAs
91 to 100 kV: 280 mAs
101 to 110 kV: 250 mAs
111 to 120 kV: 220 mAs
121 to 133 kV: 200mAs</p> <p>b) In case of FPD device radiography (after FPD upgrade)</p> <p>Large focus
40 to 50 kV: 200 mAs
51 to 60 kV: 160 mAs
61 to 80 kV: 125 mAs
81 to 100 kV: 100 mAs
101 to 125 kV: 80 mAs
126 to 130 kV: 63 mAs
131 to 133 kV: 50 mAs</p> <p>Small focus
40 to 60 kV: 160 mAs
61 to 80 kV: 125 mAs
81 to 100 kV: 100 mAs
101 to 125 kV: 80 mAs
126 to 130 kV: 63 mAs
131 to 133 kV: 50 mAs</p> <p>Long exposure time mode</p> <p>Large focus
40 to 65 kV: 320 mAs
66 to 80 kV: 280 mAs
81 to 85 kV: 250 mAs
86 to 100 kV: 220 mAs
101 to 105 kV: 200 mAs
106 to 125 kV: 180 mAs
126 to 133 kV: 140 mAs</p> <p>Long exposure time mode</p> <p>Small focus
40 to 65 kV: 320 mAs
66 to 80 kV: 280 mAs
81 to 100 kV: 220 mAs
101 to 125 kV: 180 mAs
126 to 133 kV: 140 mAs</p> | <p>12.5 kW type:
40 to 90 kV: 320 mAs
91 to 100 kV: 280 mAs
101 to 110 kV: 250 mAs
111 to 120 kV: 220 mAs
121 to 125 kV: 200 mAs</p> <p>(6) Minimum exposure time:
32 kW type: 1.0 msec.
12.5 kW type: 3.2 msec.</p> <p>(7) Anatomical program:
32 kW type: Total 72
(Upgrade single FPD unit: Total 144)
(Upgrade dual FPD unit: Total 216)
12.5 kW type: Total 72</p> <p>(8) X-ray tube focal spot size
32 kW type: 0.7/1.3 mm
12.5 kW type: 0.7 mm</p> <p>(9) Max. size of X-ray field:
43 cm × 43 cm (SID 1 m)</p> <p>(10) Minimum inherent filtration
X-ray tube assembly:
Equivalent to 1.5 mmAl, measured at 70 kV
Collimator:
Equivalent to 1.0 mmAl, measured at 70 kV</p> <p>(11) Drive
Drive speed:
Forward & Backward :
Approx. 5 km/h(Max.)
Grade ability : Maximum 7 degree</p> <p>(12) This unit is not explosion-proof type.</p> |
|---|--|--|

SPECIFICATIONS OF MAIN UNIT

- (1) Rating
- Maximum tube voltage:
32 kW type: 133 kV
12.5 kW type: 125 kV
 - Maximum tube current:
32 kW type: 400mA
12.5 kW type: 160 mA
 - Maximum power
32 kW type: 32 kW (20 msec)
12.5 kW type: 12.5 kW (0.1 sec.)
 - Nominal power
32 kW type: 16 kW (0.1 sec.)
12.5 kW type: 12.5 kW (0.1 sec.)
- (2) Power supply
batteries: 12 V × 20 pcs

SPECIFICATIONS OF X-RAY TUBE ASSEMBLY

- (1) Nominal X-ray tube voltage:
32 kW type: 133 kV
12.5 kW type: 125 kV
- (2) Nominal focal spot
32 kW type
Large focus: 1.3 mm
Small focus: 0.7 mm
12.5 kW type: 0.7 mm
- (3) Max. X-ray tube anode heat capacity : 300 kHU (210 kJ)
- (4) Max. X-ray tube anode heat dissipation rate: 1130 HU/s (800 W)
- (5) Max. X-ray tube continuous heat input: 300 HU/s (210 W)
- (6) Max. X-ray tube assembly heat content: 1060 kHU (750 kJ)
- (7) Max. X-ray tube assembly continuous heat input: 170 HU/S (120 W)
- (8) Nominal anode input power
20 msec. 0.1 msec.
Large focus: 36.4 kW 30.5 kW
Small focus: 19.9 kW 16.8 kW
- (9) Max. filament voltage: 15 V
- (10) Max. filament current *1: 5.6 A
- (11) Target material:
Rhenium-tungsten faced on molybdenum
- (12) Target angle: 16degrees
- (13) Focal track diameter: 58mm
- (14) Anode rotation:
Direction of anode rotation is counter-clockwise as viewed from cathode side.
32 kW type:
RPM is 70 Hz: 3800 rpm (min-1) or more.
12.5 kW type:
RPM is 60 Hz: 3200 rpm (min-1) or more.
- (15) Inherent filtration:
Min. 1.5 mm Al at 70 kV
- (16) X-ray protection *2:
Less than 0.87 mGy (2.58 × 10⁻⁵ C/kg) in an hour at distance of 1 m from focus.
- (17) Min. ambient temperature: -10°C
- (18) Weight: Approx.
32 kW type: 12.8 kg
12.5 kW type: 13 kg

Remarks:

*1 This is max. value which can be used at the time of adjustment of tube current.

*2

32 kW type:

Conditions of detection for the leakage radiation are

- (1) Max. used tube input 125 kV, 120 W continuously.
- (2) Repeated radiographic loading to keep the average load to be 100 W (141 HU/s) at the max. voltage.

12.5 kW type:

Conditions of detection for the leakage radiation are

- (1) Max. used tube input 125 kV, 160 W continuously.
- (2) Repeated radiographic loading to keep the average load to be 71 W (100 HU/s) at the max. voltage.

CONFIGURATION

- (1) Inverter type high voltage generator
- (2) X-ray tube unit
32 kW type: 0.7/1.3U163C-36
12.5 kW type: 0.7U163CS-36
- (3) Collimator
R-20C
- (4) Cart

OPTION

- (1) Remote controller
- (2) Protective screen (folding)
- (3) Dose area product meter
- (4) Grid unit
- (5) Keyless entry
- (6) Dose calculator unit
- (7) Distance indicator
- (8) Changing the grip bar height
- (9) Luminous hand switch
- (10) Additional hand switch
- (11) Large cassette box
- (12) FPD upgrade (32 kW type)
- (13) Wireless LAN (32 kW type, with FPD upgrade)

(14) Second FPD Kit (32 kW type, with FPD upgrade)

(15) FPD Bag (32 kW type, with FPD upgrade) (*)

(*)Not applicable for USA/Canada market

CUSTOM SPECIFICATION

High focal point (Short column type only): Lift focal point up by 150 mm

POWER REQUIREMENTS FOR BATTERY CHARGE

- Rating: 1 kVA
- Type: Single phase, AC
- Frequency: 50/60 Hz
- Standard voltage: 100, 110, 120, 200, 220, 230, 240 V
- Impedance
Single phase 100, 110, 120 VAC: 1.0 max.
Shingle phase 200, 220, 230, 240 VAC: 4.0 max.
- Ground resistance
Ground terminal: 100 max.
Additional ground terminal: 100 max.
- Fluctuation of voltage: ±10 % from standard voltage
- Power cable length: 4 m

DIMENSIONS AND WEIGHT

Height during transportation	Tall column type : Approx. 1930 mm(76.0 inch) from floor
	Short column type : Approx. 1780 mm(70.0 inch) from floor
Focal point height	Tall column type : Approx. 600 to 2010 mm(23.6 to 79.1 inch) from floor
	Short column type : Approx. 600 to 1860 mm(23.6 to 73.2 inch) from floor
	High focal point : Approx. 750 to 2010 mm(29.5 to 79.1 inch) from floor
Arm length	635 to 1200 mm
Column rotation range	± 270°
Tube rotation around support arm	± 180°
Tube rotation around tube axis	Forward 90°, Backward 20°
Rotation of collimator	± 110°
Total weight	32 kW type: Approx. 390 kg (with FPD upgrade: 420 kg)
	12.5 kW type: Approx. 370 kg

DIMENSIONS unit : mm

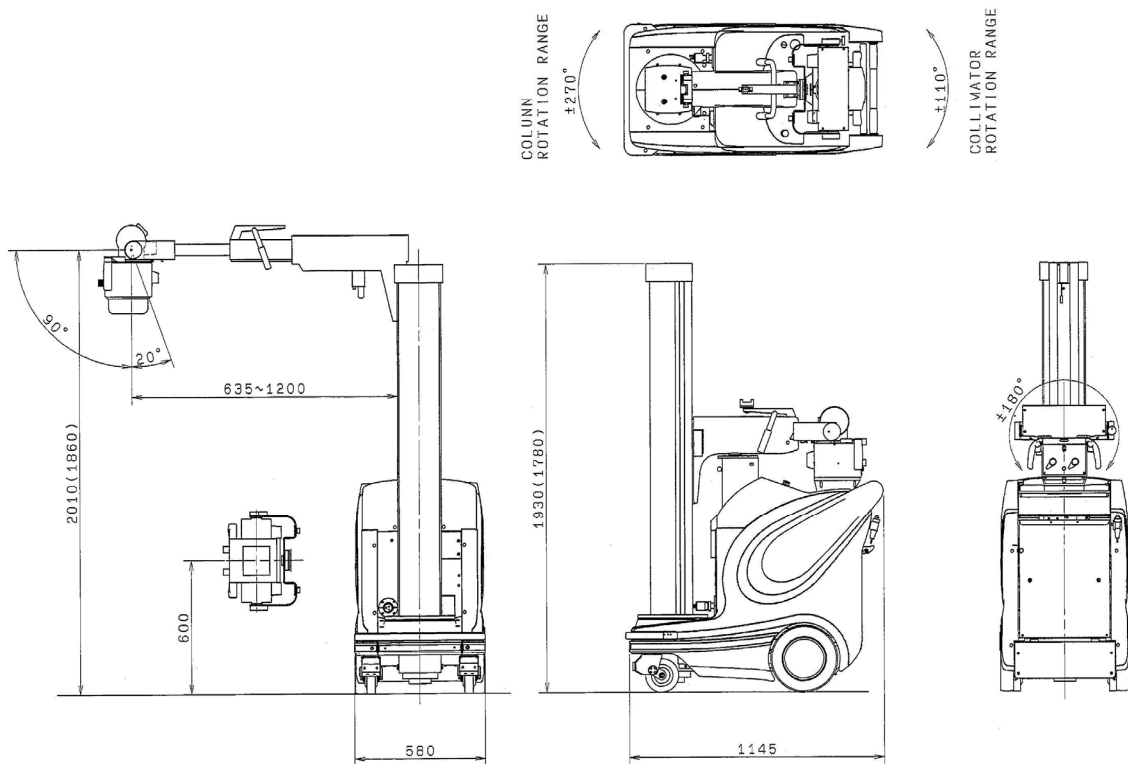

*Values shown in () are for Type S

After FPD Upgrade
(32 kW type only)

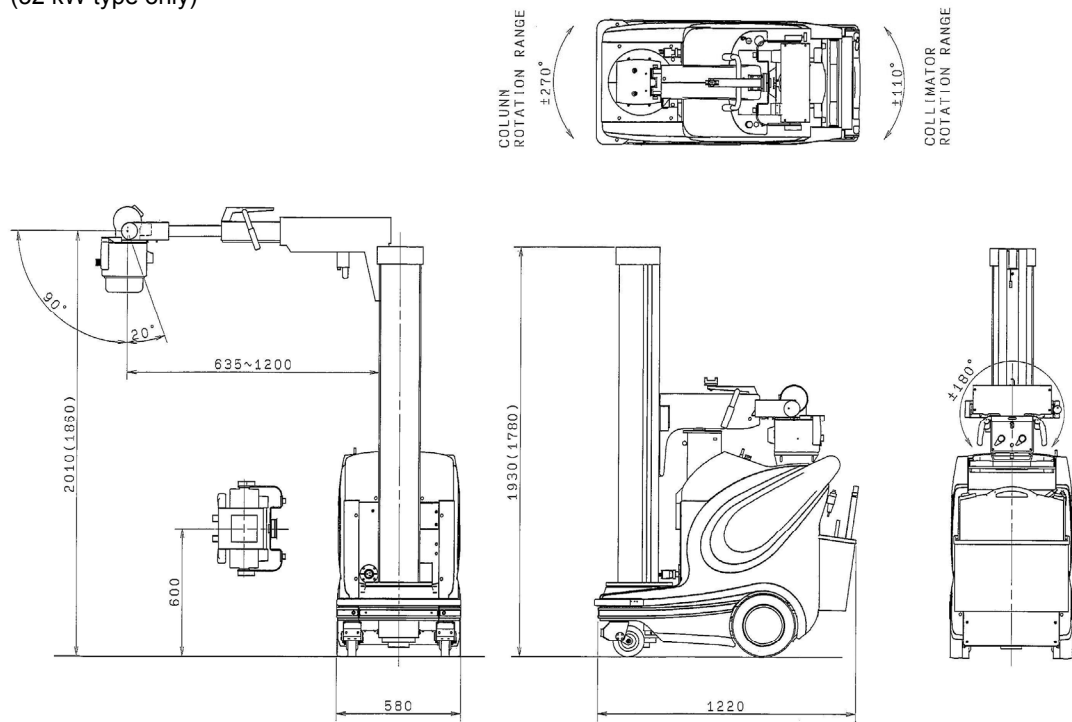

*Values shown in () are for Type S

Remarks

- * Every value in this Product Data Sheet is a standard value, and it may vary a little from the actual at each site.
- * The appearances and specifications are subject to change for reasons of improvement without notice.
- * Certain configurations may not be available pending regulatory clearance. Contact your Shimadzu representative for information on specific configurations.



SHIMADZU CORPORATION. International Marketing Division

3. Kanda-Nishikicho 1-chome, Chiyoda-ku, Tokyo 101-8448, Japan Phone: 81(3)3219-5641 Fax: 81(3)3219-5710

URL <http://www.shimadzu.com>

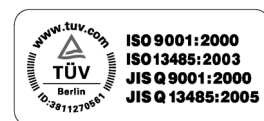

Shimadzu Corporation Medical Systems Group has been certified by TUV Rheinland as a manufacturer of medical equipment and systems in compliance with ISO9001: 2000 Quality Management Systems and EN ISO13485: 2003 Medical Equipment Quality Management Systems.