

Artwork and Signature File for:

MAN-01287 “DICOM CONF. STATEMENT, SEL V3.4”

Artwork consists of:

- Fifty-Nine (59) 8 ½ inch x 11 inch sheets attached.

REV AUTHORED BY	DATE	HOLOGIC™	SIGNATURES ON FILE	
A. TAMBASCIO	03/27/09			
REV DRAFTED BY	DATE			
J. SHARP	04/01/09			
PROPRIETARY INFORMATION: The content of this document is the exclusive property of Hologic and may not, without prior written permission of Hologic, be reproduced, copied or used for any purpose whatsoever.	TITLE	DOCUMENT NUMBER	REV	
	DICOM CONFORMANCE STATEMENT, SEL V3.4	AW-03167	001	
	ARTWORK	SIZE A	SHEET 1 OF 1	

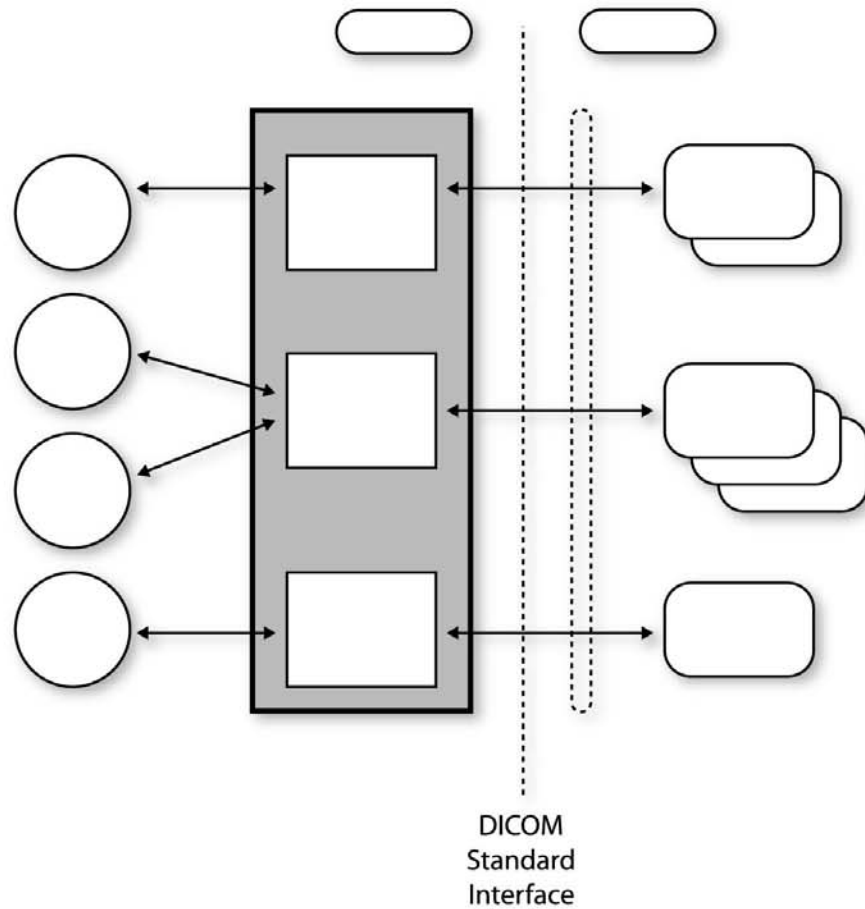

DICOM Conformance Statement for Selenia Acquisition Workstation Software Version 3.4





Selenia DICOM Conformance Statement
Part Number MAN-01287
Revision 001
For Software version 3.4

March 2009

Service Support:

USA: 877-371-4372

Europe: +32.2.711.4690

All Other: 781-999-7750

HOLOGIC™

Corporate Headquarters

35 Crosby Drive,
Bedford, MA 01730-1401 USA
Tel: 781.999.7300
Sales: 781.999.7453
Fax: 781.280.0668
www.hologic.com

Europe

(EU Representative)

Hologic NV
Leuvensesteenweg 250A
1800 Vilvoorde, Belgium
Tel: +32.2.711.4680
Fax: +32.2.725.2087

Asia Pacific

Suite 1705, Tins Enterprises Centre,
777 Lai Chi Kok Road, Cheung Sha Wan
Kowloon, Hong Kong
Tel: +852.3526.0718
Fax: +1.781.280.0668
Fax: +1.781.280.0668



© Copyright Hologic 2009. All rights reserved. Printed in USA. This manual was originally written in English.

Hologic and the Hologic Logo are trademarks or registered trademarks of Hologic, Inc. Other trademarks registered or used by Hologic and its divisions and subsidiaries in the United States and other countries include: Affinity, Affinity Platinum, Auto Film ID, "Clarity of Vision", Dimensions, DSM, FAST Paddle, Fully Automated Self-Adjusting Tilt, HTC, Lorad, "Lorad A Hologic Company", Lorad DSM, MIMS-plus, M-IV, MultiCare, ScoutMarc, SecurView, Selenia, Selenia Dimensions, Selenia TechMate, SmartWindow, StereoLoc, and TechMate. Solaris, Sun, Sun Blade, Sun Ultra, and Ultra are trademarks or registered trademarks of Sun Microsystems, Inc. in the United States and other countries. Microsoft and Windows are trademarks or registered trademarks of Microsoft Corporation in the United States and other countries. Any other product and company names mentioned herein are the trademarks or registered trademarks of their respective owners.

Table of Contents

1.0	OVERVIEW	5
2.0	INTRODUCTION.....	6
2.1.	AUDIENCE	6
2.2.	REMARKS	6
2.3.	DEFINITIONS, TERMS AND ABBREVIATIONS	7
2.4.	REFERENCES	7
3.0	NETWORKING.....	8
3.1.	IMPLEMENTATION MODEL	8
3.1.1	<i>Application Data Flow.....</i>	8
3.1.2	<i>Functional Definition of AE's.....</i>	9
3.1.3	<i>Sequencing of Real World Activities.....</i>	11
3.2.	AE SPECIFICATIONS	13
3.2.1	<i>Modality Worklist Client AE.....</i>	13
3.2.2	<i>Modality PPS Client AE.....</i>	17
3.2.3	<i>Print Client AE.....</i>	21
3.2.4	<i>Storage Client AE</i>	27
3.2.5	<i>Storage Commitment Client AE.....</i>	30
3.2.6	<i>Query/Retrieve Client AE.....</i>	33
3.2.7	<i>Storage Server AE.....</i>	37
3.2.8	<i>Verification SCP</i>	38
3.3.	NETWORK INTERFACES	40
3.3.1	<i>Physical Network Interface.....</i>	40
3.3.2	<i>Additional Protocols</i>	40
3.4.	CONFIGURATION	40
3.4.1	<i>AE Title/Presentation Address Mapping.....</i>	40
3.4.2	<i>Configuration Parameters for Local AEs</i>	42
4.0	MEDIA INTERCHANGE.....	44
4.1.	IMPLEMENTATION MODEL	44
4.1.1	<i>Application Data Flow Diagram</i>	44
4.1.2	<i>Functional Definition of AEs</i>	44
4.1.3	<i>Sequencing of Real World Activities.....</i>	45
4.1.4	<i>File Meta Information for Implementation Class Version</i>	45
4.2.	AE SPECIFICATIONS	45
4.2.1	<i>Media Server AE Specification</i>	45
4.3.	AUGMENTED AND PRIVATE APPLICATION PROFILES.....	46
4.4.	MEDIA CONFIGURATION	46

5.0	SUPPORT OF CHARACTER SETS	47
6.0	SECURITY	47
7.0	ANNEXES.....	47
7.1.	IOD CONTENTS.....	47
7.1.1	<i>Created SOP Instance(s).....</i>	<i>47</i>
7.1.2	<i>Usage of Attributes from Received IODs.....</i>	<i>56</i>
7.1.3	<i>Attribute Mapping.....</i>	<i>56</i>
7.1.4	<i>Coerced/Modified Attributes.....</i>	<i>58</i>
7.2.	DATA DICTIONARY OF PRIVATE ATTRIBUTES	58
7.3.	CODED TERMINOLOGY AND TEMPLATES	58
7.4.	GRAYSCALE IMAGE CONSISTENCY	58
7.5.	STANDARD EXTENDED/SPECIALIZED/PRIVATE SOP CLASSES	58
7.6.	PRIVATE TRANSFER SYNTAXES.....	59
8.0	SELENIA DICOM SERVICES WHEN USING STEREOLOC II OPTION.....	59
8.1.	OVERVIEW	59

1.0 Overview

The Hologic Selenia Acquisition Workstation implements the necessary DICOM services to download work lists from an information system, send acquired Digital Mammography For Processing and/or For Presentation images to a networked storage device or CD-R, request Storage Commitment from a networked storage device, send performed procedure status to a networked device, query for Hologic Digital Mammography For Processing or For Presentation images from a networked storage device, retrieve Hologic Digital Mammography For Processing or For Presentation images from a networked storage device or CD-R, and print to a networked hardcopy device.

Note: Refer to section 8.0 for information regarding DICOM functionality when the Selenia Digital StereoLoc II option is enabled and stereotactic images are being acquired.

Table 1-1 provides an overview of the network services supported by the Selenia Acquisition Workstation.

*Table 1-1
NETWORK SERVICES*

SOP Classes	User of Service (SCU)	Provider of Service (SCP)
Transfer		
Digital Mammography X-Ray Image Storage – For Presentation	Yes	Option
Digital Mammography X-Ray Image Storage – For Processing	Yes	Option
Print Management		
Basic Grayscale Print Management Meta SOP Class	Yes	No
Print Job SOP Class	Option	No
Workflow Management		
Modality Worklist Information Model – FIND	Option	No
Modality Performed Procedure Step SOP Class	Option	No
Storage Commitment Push Model SOP Class	Option	No
Query/Retrieve		
Study Root Query/Retrieve Information Model - FIND	Option	No
Study Root Query/Retrieve Information Model – MOVE	Option	No

Table 1-2 provides an overview of the Media Storage Application Profiles supported by the Selenia Acquisition Workstation.

*Table 1-2
MEDIA SERVICES*

Media Storage Application Profile	Write Files (FSC or FSU)	Read Files (FSR)
Compact Disk - Recordable		
General Purpose CD-R	Yes	Yes

2.0 Introduction

Hologic, Inc. develops and markets a full line of mammography products including the LORAD Selenia full-field digital mammography system.

The Selenia Acquisition Workstation is a component of the LORAD Selenia system. It provides an interface to the amorphous selenium X-ray detector as an image acquisition device—routing acquired images and accompanying information to output devices through DICOM interfaces. The Acquisition Workstation uses a graphical user interface (GUI) with a keyboard, pointing device (trackball), and monitor.

2.1. Audience

This document contains the DICOM conformance claim for the Selenia Acquisition Workstation. This document is intended to aid in connecting the Acquisition Workstation to other components that make use of the DICOM standard for interconnecting networked imaging devices.

The information within this document applies to Selenia AWS Software version 3.4. The reader of this document should be familiar with the DICOM standard and PACS components that utilize the standard.

2.2. Remarks

A DICOM conformance statement—the structure and content of which are stipulated by the DICOM standard—is intended to aid in determining the suitability of interconnecting digital imaging devices. References to specific functionality in a conformance statement are not sufficient to guarantee interoperability between components. The following should be considered when evaluating interoperability:

- The Acquisition Workstation conformance statement provides a starting point for ascertaining whether the product can communicate with other systems.
- The only way to know for certain whether the Acquisition Workstation can interoperate with other systems is to perform connectivity testing.
- This document represents a best effort to document the functionality of commercial versions of the Acquisition Workstation and is not a functional specification of any Hologic component or product. Hologic reserves the right to make changes at any time to the functionality of the DICOM components described herein, and is committed to following the evolution of the DICOM standard.

2.3. Definitions, Terms and Abbreviations

Amorphous Selenium: Semiconductor material used in the direct capture X-ray detector of the Selenia.

ACR: American College of Radiology

AE: Application Entity

AWS: Acquisition Workstation

CID: DICOM Context Identifier

CD-R: Compact Disk - Recordable

DICOM: Digital Imaging and Communications in Medicine

Direct Capture: Technique used to convert X-ray energy directly into electrical signals without using intensifying screens or scintillation.

FSC: File-set Creator

FSR: File-set Reader

HIPAA: Health Insurance Portability and Accountability Act

IOD: Information Object Definition

LUT: Lookup Table

MPPS: Modality Performed Procedure Step

MWL: Modality Worklist

NEMA: National Electrical Manufacturers Association

PDU: Protocol Data Unit

Q/R: Query/Retrieve

SCP: Service Class Provider

SCU: Service Class User

SOP: Service Object Pair

TCP/IP: Transmission Control Protocol/Internet Protocol

2.4. References

- ACR-NEMA DICOM Standard, 2007
- Selenia Digital StereoLoc II DICOM Conformance Statement – MAN-00750

3.0 Networking

3.1. Implementation Model

3.1.1 Application Data Flow

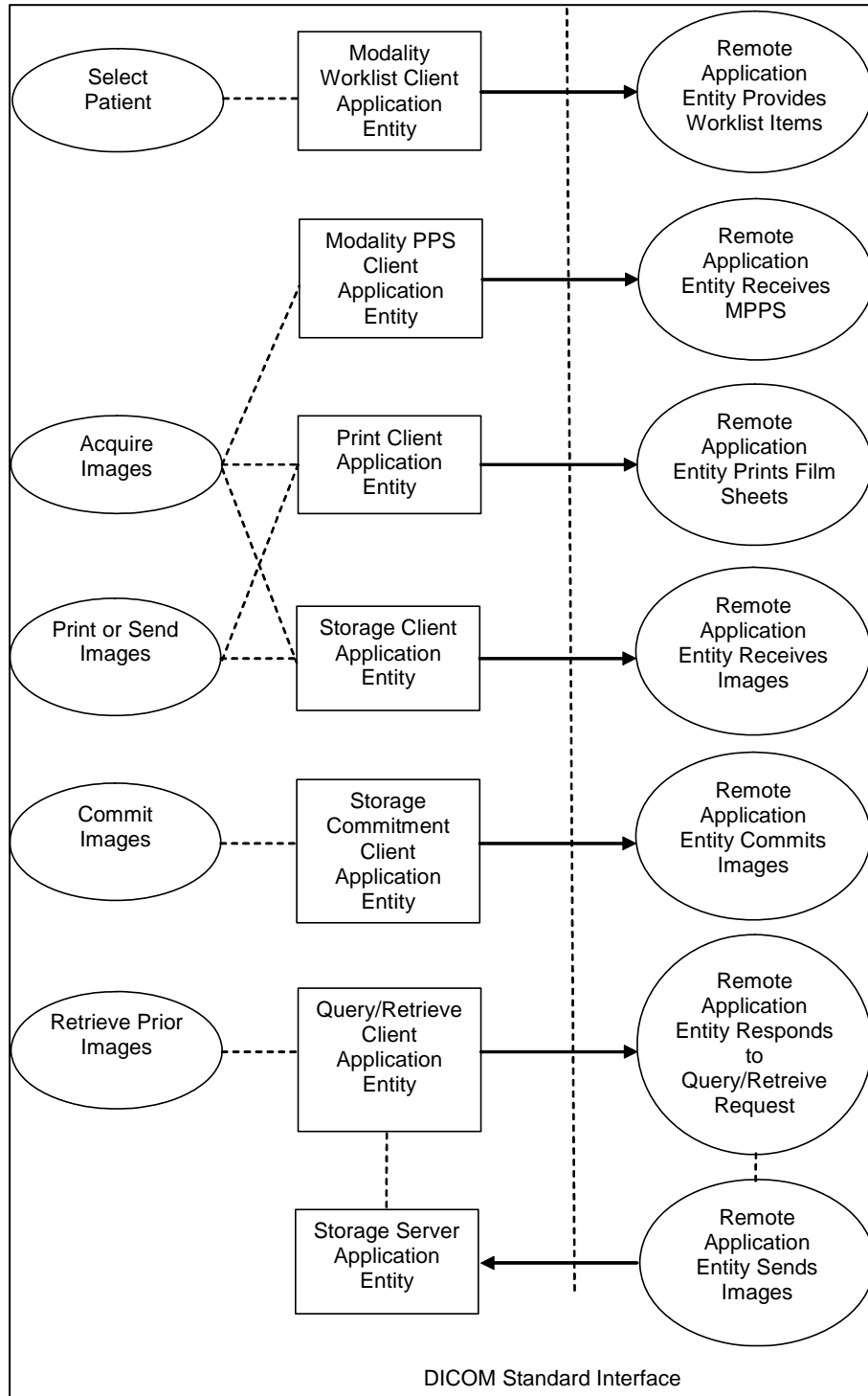

- The Modality Worklist Client Application Entity requests and receives Worklist information from a remote AE containing patient schedule and procedure information. It is associated with the local real-world activity “Select Patient”. “Select Patient” is performed as a result of a user request or can be performed automatically at specific time intervals. The Modality Worklist Client queries a remote AE for worklist items and provides to the user the set of worklist items matching the query request.
- The Modality Performed Procedure Step (PPS) Client Application Entity sends MPPS information to a preconfigured remote AE. It is associated with the local real-world activity “Acquire Images”. When the “Acquire Images” local real-world activity is performed, the Modality PPS Client creates and updates MPPS instances managed by the remote AE. Accepting or rejecting the first acquired image results in automated creation of a MPPS instance. User actions to complete, pend, or discontinue an imaging procedure results in automated update of a MPPS instance.
- The Print Client Application Entity prints images to film on a remote AE (Printer). It is associated with the local real-world activities “Acquire Images” and “Print or Send Images”. When a user performs the “Acquire Images” local real-world activity, remote AE destinations are selected to receive images either individually as they are acquired and accepted, or as a group at the close of the procedure. “Print or Send Images” is performed upon user request for a selected procedure or specific images. When a selected remote AE is a Printer, the Print Client creates a print job within the print queue containing one or more virtual film sheets composed from the acquired or selected images.
- The Storage Client Application Entity sends images to a remote AE. It is associated with the local real-world activities “Acquire Images” and “Print or Send Images”. When a user performs the “Acquire Images” local real-world activity, remote AE destinations are selected to receive images either individually as they are acquired and accepted, or as a group at the close of the procedure. “Print or Send Images” is performed upon user request for a selected procedure or specific images to be sent to one or more remote AEs. If the remote AE is configured as an archive device with storage commitment enabled, the “Commit Images” local real-world activity is triggered.
- The Query/Retrieve Client Application Entity queries and retrieves images. “Retrieve Prior Images” is performed upon user request. The Query/Retrieve Client queries a remote AE for patient studies and provides the list of studies matching the query request. Through “Retrieve Prior Images” the user selects patient studies to be retrieved. The Query/Retrieve Client issues a retrieve request for the selected patient studies.
- The Storage Server Application Entity is triggered as a result of the Query/Retrieve Client Application Entity issuing a retrieve request, and receives images from a remote AE.

3.1.2 Functional Definition of AE's

Multiple local Application Entities may be active simultaneously.

3.1.2.1 Functional Definition of Modality Worklist Client Application Entity

The Modality Worklist Client AE attempts to download a worklist from a remote node. If the Modality Worklist Client establishes an Association to a remote AE, it will accept all worklist item responses via the open Association. User interactive query results are displayed in a temporary list that is not stored. Automated query results are stored in a worklist that is replaced with each worklist download. While receiving the worklist responses, if the configurable limit of items is exceeded, an error is reported to the user and the worklist is not updated.

Note: The Modality Worklist Client Application Entity requests Worklist information from a remote AE also when the Selenia Digital StereoLoc II option is enabled.

3.1.2.2 Functional Definition of Modality PPS Client Application Entity

The Modality PPS Client AE automatically creates a MPPS instance for the remote AE after the first image for a procedure is acquired. Updates to MPPS instances are sent automatically to the remote AE when the user selects to close a procedure with Complete, Pend, or Discontinue. The user may update MPPS instances to Completed or Discontinued manually in the PPS Listing user interface.

Note: The Modality Performed Procedure Step (PPS) Client Application Entity is not available when the Selenia Digital StereoLoc II option is used to acquire stereotactic images.

3.1.2.3 Functional Definition of Print Client Application Entity

When an internal request to create a hardcopy of image data is generated, the Print Client AE will become active. The print job is created and resides in the Print Queue. The Print Client then attempts to establish an association with the remote printer. If the printer is operating normally, the film sheets described within the print job will be printed. Changes in printer status (e.g., out of film) are detected and reported to the user. If the printer is not operating normally, the print job will be set to an error state and retried. The user is notified when a request does not complete successfully. The user may also view the status of the Print Queue.

When the Print Job SOP Class is configured, a configured print job timeout controls how long Associations remain open waiting for the print job to complete. When the Print Job SOP Class is not used, the established Association remains open until the printer responds to a status request that is sent after print action is requested, or until the Print Client times out waiting for a response.

Note: The Selenia Print Client Application Entity is not available when the Selenia Digital StereoLoc II option is used to acquire stereotactic images. Refer to the Selenia Digital StereoLoc II DICOM Conformance Statement for information regarding DICOM print when the Selenia Digital StereoLoc II option is enabled and stereotactic images are being acquired.

3.1.2.4 Functional Definition of Storage Client Application Entity

The existence of a send job in the output queue will activate the Storage Client AE. An association request is sent to the destination AE and upon successful negotiation of a Presentation Context the image transfer is started. If the association cannot be opened or the store request fails, the related send job is set to an error state and can be restarted by the user via job control interface. For some error conditions, such as timeouts, the Storage Client will attempt to resend a failed send job automatically. The retry timer and retry count can be configured for the Storage Client. The user is notified when a send job does not complete successfully. The user may also view the status of output queues.

Note: The Selenia Storage Client Application Entity is not available when the Selenia Digital StereoLoc II option is used to acquire stereotactic images. Refer to the Selenia Digital StereoLoc II DICOM Conformance Statement for information regarding the Storage Client Application Entity when the Selenia Digital StereoLoc II option is used to acquire stereotactic images.

3.1.2.5 Functional Definition of Storage Commitment Client Application Entity

The existence of a commit job in the output queue will activate the Storage Commitment Client AE. An association request is sent to the destination AE and upon successful negotiation, commitment of the image is requested. The Storage Commitment Client AE waits for commitment confirmation on a separate association. The listen port is active only while waiting for commitment confirmation.

If the commit request association cannot be opened or the commit request fails, the related commit job is set to an error state and can be restarted by the user via job control interface. For some error conditions, such as timeouts, the Storage Commitment Client will attempt to resend a failed commit job request automatically. The retry timer and retry count can be configured for the Storage Commitment Client. The user is notified if the remote AE does not accept a commit job request. The user may also view the status of output queues.

Note: The Selenia Storage Commitment Client Application Entity is not available when the Selenia Digital StereoLoc II option is used to acquire stereotactic images. Refer to the Selenia Digital StereoLoc II DICOM Conformance Statement for information regarding the Storage Commitment Client Application Entity when the Selenia Digital StereoLoc II option is used to acquire stereotactic images.

3.1.2.6 Functional Definition of Query/Retrieve Client Application Entity

The Query/Retrieve Client AE is activated when a user initiates a query job to a remote AE. An association request is sent to the remote AE and upon successful negotiation, a query is sent to the remote AE. The query content is based on the query job and the configured query method (e.g., relational vs. hierarchical). Given the query results, user selection of a study to be retrieved from the remote AE triggers the Query/Retrieve Client to send a retrieve request, and invokes the Storage Server AE to become active to receive the study. If an association cannot be opened or the query or retrieve request fails, an error is generated to notify the user, and the query job is deleted.

Note: The Selenia Query/Retrieve Client Application Entity is not available when the Selenia StereoLoc II option is used to acquire stereotactic images. Refer to the Selenia Digital StereoLoc II DICOM Conformance Statement for information regarding the Query/Retrieve Client Application Entity when the Selenia Digital StereoLoc II option is used to acquire stereotactic images.

3.1.2.7 Functional Definition of Storage Server Application Entity

The Storage Server AE is active (i.e., listen port is active) only during retrieval of images requested by the Query/Retrieve Client AE from a remote AE. After retrieval of the requested images is completed, the Storage Server is no longer active. The received instances are stored to a temporary directory and then imported to the database, from which they may be listed and viewed through the user interface.

Note: The Selenia Storage Server Application Entity is not available when the Selenia Digital StereoLoc II option is used to acquire stereotactic images. Refer to the Selenia Digital StereoLoc II DICOM Conformance Statement for information regarding the Storage Server Application Entity when the Selenia Digital StereoLoc II option is used to acquire stereotactic images.

3.1.3 Sequencing of Real World Activities

A user initiates DICOM storage or print by selecting one or more output devices from a list, and then acquiring and accepting a digital mammography image. Depending on configuration, the image is transmitted to the selected remote AEs immediately, or all accepted images are transmitted when the user closes the procedure. When Storage Commitment is enabled, a storage commitment request is sent for each image that is stored successfully. The user may also initiate DICOM storage or print separate from the image acquisition procedure by selecting one or more images from a list of patient studies and selecting a destination. This is the default behavior of the system. There are other configurations that may result in different behaviors.

In cases where error(s) occur during transmission, the affected job(s) will be retried if the error condition is temporary—otherwise it will be cancelled. The user is always notified when an error occurs. The user may be able to cancel the job if desired (depending on the error condition).

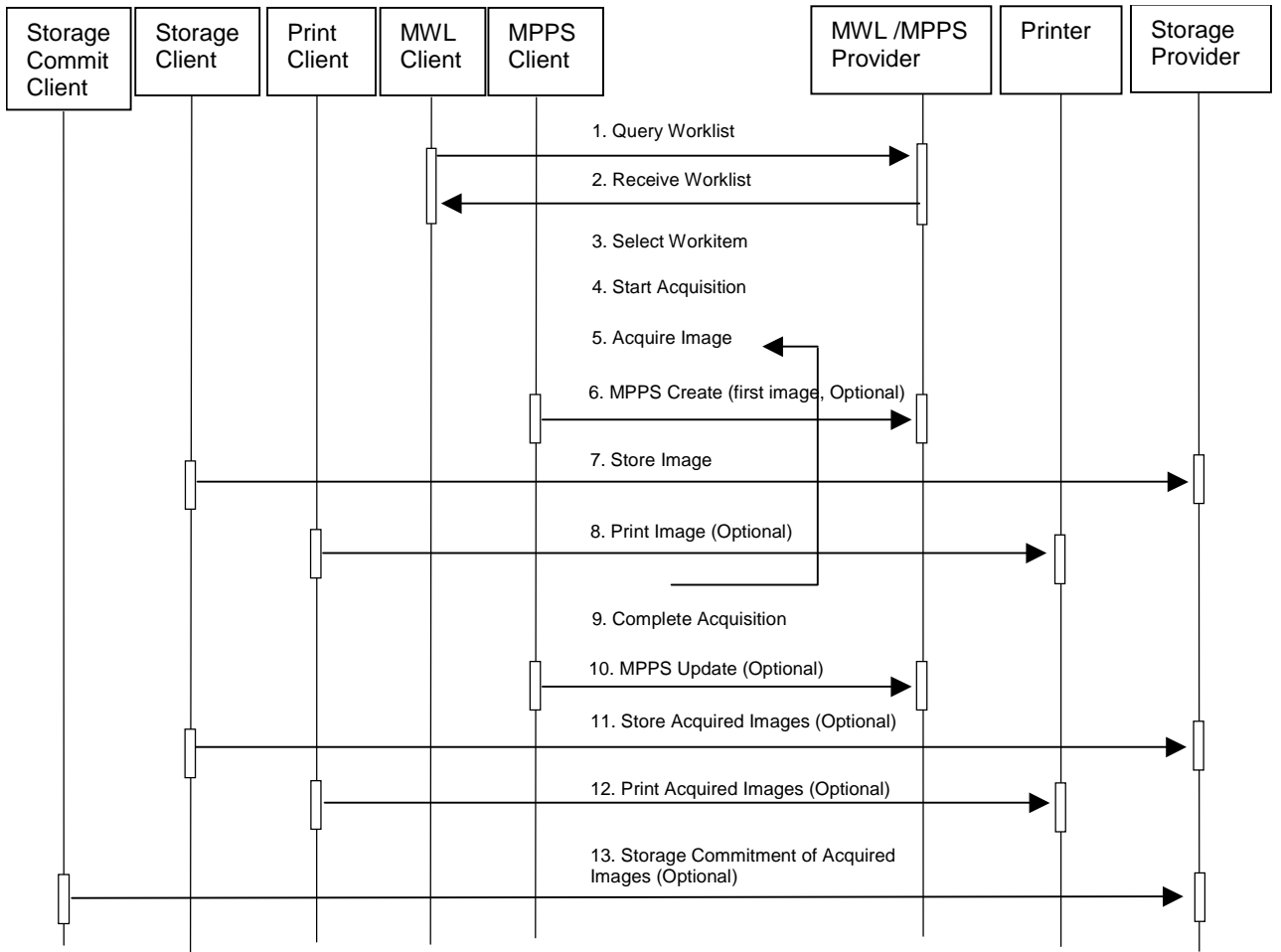

Figure 3.1-1: Image Acquisition Sequence Diagram

A user initiates DICOM query/retrieve by entering patient search criteria and executing a query. The matching patient's studies are displayed to the user. The user selects studies to retrieve and executes a retrieve request. The Acquisition Workstation receives the selected studies sent by the Query/Retrieve Provider, via the Storage Server AE

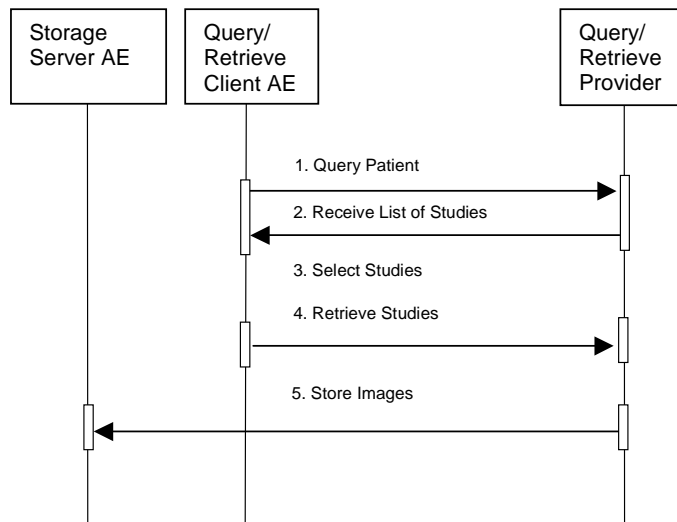

Figure 3.1-2: Query/Retrieve Sequence Diagram

3.2. AE Specifications

3.2.1 Modality Worklist Client AE

3.2.1.1 SOP Classes

This Application Entity provides Standard Conformance to the following SOP Class:

*Table 3.2.1-1
SOP CLASS FOR MODALITY WORKLIST CLIENT AE*

SOP Class Name	SOP Class UID	SCU	SCP
Modality Worklist Information Model - FIND	1.2.840.10008.5.1.4.31	Yes	No

3.2.1.2 Association Policies

3.2.1.2.1 General

The DICOM standard Application context shall be specified.

*Table 3.2.1-2
DICOM APPLICATION CONTEXT*

Application Context Name	1.2.840.10008.3.1.1.1
--------------------------	-----------------------

3.2.1.2.2 Number of Associations

One association is initiated at a time for the Modality Worklist Client AE.

3.2.1.2.3 Asynchronous Nature

The Acquisition Workstation does not support asynchronous operations (multiple outstanding transactions over a single Association).

3.2.1.2.4 Implementation Identifying Information

*Table 3.2.1-3
DICOM IMPLEMENTATION CLASS AND VERSION FOR MODALITY WORKLIST CLIENT*

Implementation Class UID	1.2.840.114089.1.0.0.2.7.6
Implementation Version Name	DCF 2.7.6b

3.2.1.3 Association Initiation Policy

3.2.1.3.1 Select Patient

3.2.1.3.1.1 Description and Sequencing of Activities

The Select Patient request for a Modality Worklist update is initiated by user interaction, or automatically at defined periods (polling). When the user initiates Select Patient, the user enters data to be used as search criteria, and the data entered by the user are used as matching keys in the query. The search criteria (query keys) and return key attributes for user-entered queries and automatic updates are site configurable.

When an internal request for Modality Worklist update is received, the Modality Worklist Client attempts to establish an association with the configured remote AE. When the association is established a C-FIND request is made to retrieve a worklist using the defined matching and return keys. The Modality Worklist Client waits for C-FIND responses to be returned. The established association remains active until a C-FIND response from the remote AE indicates the end of worklist items, or until a configurable timeout period expires. The Modality Worklist Client limits the number of stored worklist responses to a configurable maximum. If the maximum is exceeded during an interactive query, the user is notified that the maximum number of responses was exceeded. For an automatic query, an

alarm is posted. In either case, when the maximum is exceeded none of the responses are displayed or stored.

The activity of the Modality Worklist Client is transparent to the user. The Modality Worklist Client queries the remote AE using the C-FIND operation and displays the returned worklist items. The user selects a worklist item to begin an exam. The Acquisition Workstation incorporates information from the selected worklist item into the acquired image object. The quality of the information returned in worklist items directly impacts the efficiency of the user. When the remote AE returns insufficient information or is off-line, the Acquisition Workstation requires the user to manually enter information used to identify the patient and procedure.

3.2.1.3.1.2 Proposed Presentation Contexts

The Modality Worklist Client attempts to establish associations using the following presentation contexts:

*Table 3.2.1-4
PROPOSED PRESENTATION CONTEXTS FOR SELECT PATIENT*

Presentation Context Table					
Abstract Syntax		Transfer Syntax		Role	Extended Negotiation
Name	UID	Name List	UID List		
Modality Worklist Information Model - FIND	1.2.840.10008.5.1.4.31	Implicit VR, Little Endian	1.2.840.10008.1.2	SCU	None

3.2.1.3.1.3 SOP Specific Conformance for Modality Worklist

The behavior of the Acquisition Workstation when encountering status codes in a Modality Worklist C-FIND response is summarized in the Table below. If the Acquisition Workstation receives a SCP response status other than "Success" or "Pending", the user is notified.

*Table 3.2.1-5
DICOM COMMAND RESPONSE STATUS HANDLING BEHAVIOR*

Service Status	Further Meaning	Error Code	Behavior
Success	Matching is complete	0000	The SCP has completed the matches. Worklist items are available for display. However, if more than the configured maximum number of responses were received, the AWS aborts the association and posts an error message to the user.
Pending	Matches are continuing	FF00	The worklist item contained in the Identifier is collected for later display.
Refused	Out of resources	A700	AWS Aborts association. Error message to user indicates "DimseException: Out of resources"
Failed	Identifier does not match SOP Class	A900	AWS Aborts association. Error message to user indicates "DimseException: Data set does not match (error)"
Failed	Unable to process	Cxxx	AWS Aborts association. Error message to user indicates "DimseException: Cannot understand"

The behavior of the Acquisition Workstation during communication failure is summarized in the Table below.

*Table 3.2.1-6
DICOM COMMAND COMMUNICATION FAILURE BEHAVIOR*

Exception	Behavior
Timeout	The Association is aborted and an error message is posted to the user.
Association aborted by SCP	The error message "remote AE aborted association" is posted to the user, and no worklist items are displayed.

The Modality Worklist Client is designed to function using a configurable query strategy. The query strategy defines:

- Query method (on-demand, polling, or both)
- Matching keys used
- Return keys requested
- Timeout parameters
- User displayed attributes

The Acquisition Workstation stores modality worklist items that have been obtained using polling in a configurable location.

For user interactive queries Modality Worklist Client supports any combination of the following matching key attributes:

Table 3.2.1-7 – MWL SOP Class: Supported Matching Keys – User Interactive Queries

Matching Key Attribute	Tag	Matching Type
Patient's Name	(0010,0010)	Wild Card Matching
Patient ID	(0010,0020)	Single Value Matching
Accession Number	(0008,0050)	Single Value Matching
Requested Procedure ID	(0040,1001)	Single Value Matching
Scheduled Procedure Step Start Date	(0040,0002)	Range Matching

For automated queries the Modality Worklist Client supports any combination of the following matching key attributes:

Table 3.2.1-8 – MWL SOP Class: Supported Matching Keys – Automated Queries

Matching Key Attribute	Tag	Matching Type
Modality	(0008,0060)	Single Value Matching (default "MG")
Scheduled Procedure Step Start Date	(0040,0002)	Range Matching
Scheduled Station Name	(0040,0010)	Single Value Matching (Configurable Text)
Current Patient Location	(0038,0300)	Single Value Matching (Configurable Text)
Scheduled Station AE Title	(0040,0001)	Single Value Matching (Configurable Text)

The Modality Worklist Client can be configured to request any combination of return key attributes. Table 3.2.1-9 contains the default list of attributes that may be requested. Unexpected attributes returned in a C-FIND response are ignored. Requested return key attributes that are not supported by the Modality Worklist SCP are set to have no value.

Table 3.2.1-9 – Modality Worklist SOP Class: Requested Return Key Attributes

Module/Attribute	Tag
SOP Common	
Specific Character Set	(0008,0005)
Scheduled Procedure Step	
Scheduled Procedure Step Sequence	(0040,0100)
> Scheduled Station AE Title	(0040,0001)
> Scheduled Procedure Step Start Date	(0040,0002)
> Scheduled Procedure Step Start Time	(0040,0003)
> Modality	(0008,0060)
> Scheduled Performing Physician's Name	(0040,0006)
> Scheduled Procedure Step Description	(0040,0007)
> Scheduled Station Name	(0040,0010)
> Scheduled Procedure Step Location	(0040,0011)
> Scheduled Protocol Code Sequence	(0040,0008)
>> Code Value	(0008,0100)
>> Coding Scheme Designator	(0008,0102)
>> Code Meaning	(0008,0104)
> Scheduled Procedure Step ID	(0040,0009)
> Comments on the Scheduled Procedure Step	(0040,0400)
Requested Procedure	
Requested Procedure ID	(0040,1001)
Requested Procedure Description	(0032,1060)
Requested Procedure Code Sequence	(0032,1064)
> Code Value	(0008,0100)
> Coding Scheme Designator	(0008,0102)
> Code Meaning	(0008,0104)
Study Instance UID	(0020,000D)
Referenced Study Sequence	(0008,1110)
> Referenced SOP Class UID	(0008,1150)
> Referenced SOP Instance UID	(0008,1155)
Imaging Service Request	
Accession Number	(0008,0050)
Requesting Physician	(0032,1032)
Referring Physician's Name	(0008,0090)
Visit Identification	
Admission ID	(0038,0010)
Visit Status	
Current Patient Location	(0038,0300)
Patient Identification	
Patient's Name	(0010,0010)
Patient ID	(0010,0020)
Other Patient IDs	(0010,1000)
Patient Demographic	
Patient's Birth Date	(0010,0030)
Patient's Sex	(0010,0040)
Patient's Size	(0010,1020)
Patient's Weight	(0010,1030)
Patient Comments	(0010,4000)
Confidentiality Constraint on Patient Data Description	(0040,3001)
Patient Medical	
Additional Patient History	(0010,21B0)
Pregnancy Status	(0010,21C0)
Last Menstrual Date	(0010,21D0)
Patient State	(0038,0500)
Standard Extended	
Study Description	(0008,1030)

Module/Attribute	Tag
Study ID	(0020,0010)

By default the Code Value (0008,0100) attribute of the Requested Procedure Code Sequence (0032,1064) is used to select the configured RIS code and configured procedure for a given modality worklist item. The Acquisition Workstation may be configured to use an alternate attribute for the RIS code. The alternative attributes are Code Meaning (0008,0104) of Requested Procedure Code Sequence (0032,1064), Study Description (0008,1030), or from within Scheduled Procedure Step Sequence (0040,0100): Scheduled Procedure Step Description (0040,0007), Scheduled Procedure Step ID (0040,0009), Code Meaning (0008,0104) of Scheduled Protocol Code Sequence (0040,0008), or Code Value (0008,0100) of Scheduled Protocol Code Sequence (0040,0008). When the configured RIS code attribute is missing from a returned modality worklist item or the value does not match a code in the procedure database, the user is prompted to select a procedure manually.

See Section 7.1.3 for the mapping of worklist item return key attributes to acquired image attributes.

3.2.1.4 Association Acceptance Policy

The Modality Worklist Client AE does not accept associations.

3.2.2 Modality PPS Client AE

3.2.2.1 SOP Classes

This Application Entity provides Standard Conformance to the following SOP Class:

*Table 3.2.2-1
SOP CLASS FOR MODALITY PPS CLIENT AE*

SOP Class Name	SOP Class UID	SCU	SCP
Modality Performed Procedure Step	1.2.840.10008.3.1.2.3.3	Yes	No

3.2.2.2 Association Policies

3.2.2.2.1 General

The DICOM standard Application context shall be specified.

*Table 3.2.2-2
DICOM APPLICATION CONTEXT*

Application Context Name	1.2.840.10008.3.1.1.1
--------------------------	-----------------------

3.2.2.2.2 Number of Associations

One association is initiated at a time for the Modality PPS Client AE.

3.2.2.2.3 Asynchronous Nature

The Acquisition Workstation does not support asynchronous operations (multiple outstanding transactions over a single Association).

3.2.2.2.4 Implementation Identifying Information

*Table 3.2.2-3
DICOM IMPLEMENTATION CLASS AND VERSION FOR MODALITY PPS CLIENT*

Implementation Class UID	1.2.840.114089.1.0.0.2.7.6
Implementation Version Name	DCF 2.7.6b

3.2.2.3 Association Initiation Policy**3.2.2.3.1 Acquire Images****3.2.2.3.1.1 Description and Sequencing of Activities**

The trigger to create a MPPS SOP Instance is to accept or reject the first acquired image from a patient's procedure. The job to create the corresponding MPPS SOP Instance is added to the MPPS queue.

When the user selects Complete to close a procedure, a job to update the corresponding MPPS SOP Instance with final status of Completed is added to the MPPS queue.

When the user selects Pend to halt a procedure after at least one image has been accepted or rejected for the procedure, a job to update the corresponding MPPS SOP Instance with status of In Progress is added to the MPPS queue.

When the user selects Discontinue to close a procedure, a job to update the corresponding MPPS SOP Instance with final status of Discontinued is added to the MPPS queue. If no MPPS SOP Instance exists (e.g., no image was acquired for the procedure), two jobs are added to the MPPS queue, first to create a MPPS SOP Instance, then to update the MPPS SOP Instance with final status of Discontinued.

When the user changes the status of a MPPS SOP Instance to Completed or Discontinued on the PPS Listing user interface, a job to update the corresponding MPPS SOP Instance with the final status is added to the MPPS queue. A MPPS Instance that has been updated to a status of Completed or Discontinued can no longer be updated.

When the user selects to discontinue a procedure, the user may also select a preconfigured discontinuation reason from a customized list that initially is based on Context ID 9300.

The Acquisition Workstation includes attributes from the Radiation Dose module in MPPS SOP Instances when the Radiation Dose option is enabled.

The Acquisition Workstation supports creation of "unscheduled cases" by allowing MPPS Instances to be created for locally registered patients or procedures.

The Acquisition Workstation supports a 1-to-n relationship between Scheduled and Performed Procedure Steps. When a user adds one or more views to a Completed procedure, or adds a procedure to an Accession Number that already has a Completed procedure, a new MPPS SOP Instance is created for the corresponding Scheduled Procedure Step after the first image is accepted or rejected.

The Modality PPS Client AE initiates an Association with the remote MPPS SCP AE for each job in the MPPS Queue, to issue a:

- N-CREATE request for Modality Performed Procedure Step SOP Instance
- N-SET request to update the contents and status of a MPPS SOP Instance

The Modality PPS Client AE ensures that a N-CREATE request has been sent successfully for a MPPS SOP Instance prior to sending a MPPS N-SET request for the MPPS SOP Instance.

3.2.2.3.1.2 Proposed Presentation Contexts

The Modality PPS Client attempts to establish associations using the following presentation contexts:

*Table 3.2.2-4
PROPOSED PRESENTATION CONTEXTS FOR SELECT PATIENT*

Presentation Context Table					
Abstract Syntax		Transfer Syntax		Role	Extended Negotiation
Name	UID	Name List	UID List		
Modality Performed Procedure Step	1.2.840.10008.3.1.2.3.3	Implicit VR, Little Endian	1.2.840.10008.1.2	SCU	None

3.2.2.3.1.3 SOP Specific Conformance for Modality Performed Procedure Step

The behavior of the Acquisition Workstation when encountering status codes in a MPPS N-CREATE or N-SET response is summarized in the Table below. If the Acquisition Workstation receives a SCP response status other than "Success", the failure is logged. The user can check the status of MPPS jobs in the Managed Queues user interface.

*Table 3.2.2-5
DICOM COMMAND RESPONSE STATUS HANDLING BEHAVIOR*

Service Status	Further Meaning	Error Code	Behavior
Success	Success	0000	The SCP has completed the operation successfully.
Warning	Any	Any	AWS aborts association.
Failure	Any	Any	AWS aborts association.

The behavior of the Acquisition Workstation during communication failure is summarized in the Table below. Depending on the type of failure, and retry configuration, the MPPS job may be retried several times before reporting an error.

Table 3.2.2-6 - DICOM COMMAND COMMUNICATION FAILURE BEHAVIOR

Exception	Behavior
Timeout	The Association is aborted and the MPPS job is marked as failed. The reason is logged and the job status is reported in the Manage Queues user interface.
Association aborted by SCP	The MPPS job is marked as failed. The reason is logged and the job status is reported in the Manage Queues user interface.

The Modality PPS Client AE sends the following attributes in MPPS N-CREATE and N-SET requests. Empty cells indicate that the attribute is not sent.

Table 3.2.2-7 – MPPS N-CREATE / N-SET Requests

Attribute Name	Tag	N-CREATE	N-SET
Performed Procedure Step Relationship			
Patient's Name	(0010,0010)	MWL or manual entry	
Patient ID	(0010,0020)	MWL or manual entry	
Patient's Birth Date	(0010,0030)	MWL or manual entry	
Patient's Sex	(0010,0040)	MWL or manual entry	
Scheduled Step Attributes Sequence	(0040,0270)	Always present	
>Study Instance UID	(0020,000D)	MWL or generated	
>Referenced Study Sequence	(0008,1110)	MWL or not sent	
>>Referenced SOP Class UID	(0008,1150)	MWL or not sent	
>>Referenced SOP Instance UID	(0008,1155)	MWL or not sent	
>Accession Number	(0008,0050)	MWL, manual or zero length	

Attribute Name	Tag	N-CREATE	N-SET
>Requested Procedure ID	(0040,1001)	MWL, manual or zero length	
>Requested Procedure Description	(0032,1060)	MWL or zero length	
>Scheduled Procedure Step ID	(0040,0009)	MWL or zero length	
>Scheduled Procedure Step Description	(0040,0007)	MWL or zero length	
>Scheduled Protocol Code Sequence	(0040,0008)	MWL or zero length	
>>Code Value	(0008,0100)	MWL or not sent	
>>Coding Scheme Designator	(0008,0102)	MWL or not sent	
>>Code Meaning	(0008,0104)	MWL or not sent	
Performed Procedure Step Information			
Performed Procedure Step ID	(0040,0253)	Generated value	
Performed Station AE Title	(0040,0241)	Configured value	
Performed Station Name	(0040,0242)	Configured value	
Performed Location	(0040,0243)	Configured value	
Performed Procedure Step Start Date	(0040,0244)	Date first acquired image is accepted or rejected	
Performed Procedure Step Start Time	(0040,0245)	Time first acquired image is accepted or rejected	
Performed Procedure Step Status	(0040,0252)	IN PROGRESS	IN PROGRESS, COMPLETED or DISCONTINUED
Performed Procedure Step Description	(0040,0254)	Configured procedure description	Configured procedure description
Performed Procedure Type Description	(0040,0255)	Configured procedure description	Configured procedure description
Procedure Code Sequence	(0008,1032)	Same as Scheduled Protocol Code Sequence	Same as Scheduled Protocol Code Sequence
Performed Procedure Step End Date	(0040,0250)	Zero length	Date of close procedure action [zero length if still IN PROGRESS]
Performed Procedure Step End Time	(0040,0251)	Zero length	Time of close procedure action [zero length if still IN PROGRESS]
Performed Procedure Step Discontinuation Reason Code Sequence	(0040,0281)	Zero length	Zero to three Items containing user selection if Exception Management option enabled
Image Acquisition Results			
Modality	(0008,0060)	Default = MG	
Study ID	(0020,0010)	MWL or generated value	
Performed Protocol Code Sequence	(0040,0260)	Configured procedure code	Configured procedure code
>Code Value	(0008,0100)		Code value
>Coding Scheme Designator	(0008,0102)		Coding scheme designator
>Code Meaning	(0008,0104)		Code meaning
Performed Series Sequence	(0040,0340)	Zero length	One or two Items per accepted image
>Performing Physician's Name	(0008,1050)		Zero length
>Operator's Name	(0008,1070)		Current user
>Protocol Name	(0018,1030)		Same as Series Description
>Series Instance UID	(0020,000E)		Generated value
>Series Description	(0008,103E)		Configured value
>Retrieve AE Title	(0008,0054)		Zero length

Attribute Name	Tag	N-CREATE	N-SET
>Referenced Image Sequence	(0008,1140)		One or more Items
>>Referenced SOP Class UID	(0008,1150)		UID for Digital Mammography X-Ray Image – For Presentation or For Processing
>>Referenced SOP Instance UID	(0008,1155)		Generated value
Radiation Dose			
Anatomic Structure, Space or Region Sequence	(0008,2229)	Zero length if Radiation Dose option enabled	One Item (T-04000, SNM3, “Breast”) if Radiation Dose option enabled
Total Number of Exposures	(0040,0301)	Zero length if Radiation Dose option enabled	Number of acquired images if Radiation Dose option enabled
Distance Source to Detector	(0018,1110)	Zero length if Radiation Dose option enabled	Generated value if Radiation Dose option enabled
Entrance Dose	(0040,0302)	Zero length if Radiation Dose option enabled	Sum for all acquired images if Radiation Dose option enabled
Entrance Dose in mGy	(0040,8302)	Zero length if Radiation Dose option enabled	Sum for all acquired images if Radiation Dose option enabled
Exposure Dose Sequence	(0040,030E)	Zero length if Radiation Dose option enabled	One Item per acquired image if Radiation Dose option enabled
>Radiation Mode	(0018,115A)		CONTINUOUS
>KVP	(0018,0060)		Value from acquisition
>X-ray Tube Current in μ A	(0018,8151)		Value from acquisition
>Exposure Time	(0018,1150)		Value from acquisition
>Filter Material	(0018,7050)		MOLYBDENUM or RHODIUM
Standard Extended			
Organ Dose	(0040,0316)	Zero length if Radiation Dose option enabled	Calculated value
Organ Exposed	(0040,0318)	Zero length if Radiation Dose option enabled	BREAST

3.2.2.4 Association Acceptance Policy

The Modality PPS Client AE does not accept associations.

3.2.3 Print Client AE

3.2.3.1 SOP Classes

This Application Entity provides Standard Conformance to the following SOP Classes:

*Table 3.2.3-1
SOP CLASSES FOR PRINT CLIENT AE*

SOP Class Name	SOP Class UID	SCU	SCP
Basic Grayscale Print Management Meta	1.2.840.10008.5.1.1.9	Yes	No
Print Job SOP Class	1.2.840.10008.5.1.1.14	Yes	No

3.2.3.2 Association Policies

3.2.3.2.1 General

The DICOM standard Application context shall be specified.

*Table 3.2.3-2
DICOM APPLICATION CONTEXT*

Application Context Name	1.2.840.10008.3.1.1.1
--------------------------	-----------------------

3.2.3.2.2 Number of Associations

One association is initiated at a time for the Print Client AE.

3.2.3.2.3 Asynchronous Nature

The Acquisition Workstation does not support asynchronous operations (multiple outstanding transactions over a single Association).

3.2.3.2.4 Implementation Identifying Information

*Table 3.2.3-3
DICOM IMPLEMENTATION CLASS AND VERSION FOR PRINT CLIENT*

Implementation Class UID	1.2.840.114089.1.0.0.2.7.6
Implementation Version Name	DCF 2.7.6b

3.2.3.3 Association Initiation Policy

3.2.3.3.1 Acquire Images / Print or Send Images

3.2.3.3.1.1 Description and Sequencing of Activities

The Print Client attempts to establish an association with a remote print AE when an internal request to print one or more images is received. When the Print Job SOP Class is configured, the print job timeout controls how long associations remain open waiting for the print job to complete. When the Print Job SOP Class is not used, the association remains open until the remote print AE responds to a status request that is sent after print action is requested, or until the Print Client times out waiting for a response.

For requested image(s) to be printed the Print Client requests the establishment of an association with a Remote Print AE using the Basic Grayscale Print Management Meta SOP Class. If so configured the Print Client negotiates the optional Print Job SOP class.

Once an association is established the Print Client sends print jobs to the remote print AE. Each print job consists of the following steps:

- The Print Client sends the remote print AE an N-GET request for the Printer SOP Class to determine the status of the printer. The Print Client records the status and continues. The Print Client sends an N-CREATE request to the remote print AE to create a film session. After receiving a successful N-CREATE response, the Print Client then sends an N-CREATE request to the remote print AE to create a film box containing a single image box. The remote print AE creates the film session, film box, and image box.
- The Print Client sends the remote print AE an N-SET request to update the image box with the image pixel data and other information needed for the image to be printed as part of a film box.
- Once the image has been transferred the Print Client sends the remote print AE an N-ACTION request for the film box. This triggers the remote print AE to print the film. Note that the Print Client does not request N-ACTION at the film session level.

- When the Print Job SOP Class is negotiated the Print Client polls the remote print AE by sending alternate N-GET requests for the Print Job and Printer SOP Classes at pre-configured intervals until an execution status of either “FAILURE” or “DONE” is received in an N-GET response or N-EVENT-REPORT request, or until the configured job timeout period expires.
- When the Print Job SOP Class is not used, the Print Client sends one N-GET request for the Printer SOP Class after the N-ACTION response is received. The association remains open until the N-GET response or a N-EVENT-REPORT request is received, or until the Print Client times out waiting for the N-GET response.
- Before closing the association under any circumstance, the Print Client sends an N-DELETE request for the film box and then for the film session.
- An alarm is posted to the user when a printer warning or failure status message is received from the remote print AE.

3.2.3.3.1.2 Proposed Presentation Contexts

The Print Client attempts to establish associations using the following presentation contexts:

Table 3.2.3-4
PROPOSED PRESENTATION CONTEXTS FOR ACQUIRE IMAGES

Presentation Context Table					
Abstract Syntax		Transfer Syntax		Role	Extended Negotiation
Name	UID	Name List	UID List		
Basic Grayscale Print Management Meta	1.2.840.10008.5.1.9	Implicit VR, Little Endian	1.2.840.10008.1.2	SCU	None
Print Job SOP Class	1.2.840.10008.5.1.14	Implicit VR, Little Endian	1.2.840.10008.1.2	SCU	None

3.2.3.3.1.3 SOP Specific Conformance for Print Client

The general behavior of the Print Client AE during communication failure is summarized in the Table below. This behavior is common to all SOP Classes supported by the Print Client AE. Depending on the type of failure, and retry configuration, the print job may be retried several times before reporting an error to the user.

Table 3.2.3-5
DICOM COMMAND COMMUNICATION FAILURE BEHAVIOR

Exception	Behavior
Timeout	The Association is aborted and an error message is posted to the user: “Print job was not completed in the allotted time, or timeout waiting for response. Status of print job is unknown.”
Association aborted by SCP	An error message is posted to the user: “Cannot open socket to specified host/port, a network error has occurred, or received abort from remote system.”

The Print Client supports various printer types that may expect different values for the film session, film box, and image box attributes. These attribute values are defined within model files for each specific printer. This section describes the DIMSE services and the attributes supported for various remote print AEs and includes the particular attributes that may be configured per printer type.

3.2.3.3.1.3.1 Specific Conformance to Basic Film Session SOP Class

Table 3.2.3-6 - Basic Film Session SOP Class: Supported DIMSE operations

Name	Description
N-CREATE	Creates the film session
N-DELETE	Deletes the film session

Table 3.2.3-7 - Basic Film Session SOP Class: Supported Attributes

Attribute Name	Tag	Supported Values	Default Value
Number Of Copies	(2000,0010)	1-99	1
Print Priority	(2000,0020)	HIGH, MED, LOW	MED
Medium Type	(2000,0030)	BLUE FILM CLEAR FILM MAMMO BLUE FILM	BLUE FILM
Film Destination	(2000,0040)	(Configurable)	(Configurable)
Film Session Label	(2000,0050)	64 characters max.	
Memory Allocation	(2000,0060)	(Configurable)	(Configurable)

The behavior of Print Client AE when encountering status codes in a N-CREATE or N-DELETE response is summarized in the Table below.

Table 3.2.3-8

FILM SESSION SOP CLASS RESPONSE STATUS HANDLING BEHAVIOR

Service Status	Further Meaning	Error Code	Behavior
Success	Success	0000	The SCP has completed the operation successfully. Proceed to next step.
Warning	Memory allocation	B600	Proceed to next step.
Failure	Any	Any	AWS Aborts association. Error message to user indicates "A DICOM DIMSE error was returned in a response." Specific status information is logged.

3.2.3.3.1.3.2 Specific Conformance to Basic Film Box SOP Class

Table 3.2.3-9 - Basic Film Box SOP Class: Supported DIMSE operations

Name	Description
N-CREATE	Creates the film box
N-DELETE	Deletes the film box
N-ACTION	Prints the film box

Table 3.2.3-10 - Basic Film Box SOP Class: Supported Attributes

Attribute Name	Tag	Supported Values	Default Value
Image Display Format	(2010,0010)	STANDARD\1,1	STANDARD\1,1
Annotation Display Format ID	(2010,0030)	(Configurable)	Configured to printer's requirements
Film Orientation	(2010,0040)	PORTRAIT	
Film Size ID	(2010,0050)	8INX10IN 10INX12IN (Configurable per printer)	Configured per each printer's requirements with image matrix size, or set to calculate automatically for true size printing.
Magnification Type	(2010,0060)	REPLICATE BILINEAR CUBIC NONE	Configured per printer.
Smoothing Type	(2010,0080)	(Configurable)	Configured per printer.

Attribute Name	Tag	Supported Values	Default Value
Border Density	(2010,0100)	BLACK WHITE numeric, OD x 100	Configured per printer.
Empty Image Density	(2010,0110)	BLACK WHITE numeric, OD x 100	Configured per printer.
Min Density	(2010,0120)	numeric, OD x 100	Configured per printer.
Max Density	(2010,0130)	numeric, OD x 100	Configured per printer.
Trim	(2010,0140)	(Configurable)	Configured per printer.
Configuration Information	(2010,0150)	CSxxx, where xxx = Code Value obtained from printer vendors	Configured per printer.
Referenced Film Session Sequence	(2010,0500)		Returned by SCP
Referenced Image Box Sequence	(2010,0510)		Returned by SCP
Referenced Annotation Box Sequence	(2010,0520)		Returned by SCP

The behavior of Print Client AE when encountering status codes in a N-CREATE, N-ACTION, or N-DELETE response is summarized in the Table below.

*Table 3.2.3-11
FILM BOX SOP CLASS RESPONSE STATUS HANDLING BEHAVIOR*

Service Status	Further Meaning	Error Code	Behavior
Success	Success	0000	The SCP has completed the operation successfully. Proceed to next step.
Failure	Existing Film Box	C616	Proceed to next step.
Warning or Failure	Any	Any	AWS Aborts association. Error message to user indicates "A DICOM DIMSE error was returned in a response." Specific status information is logged.

3.2.3.3.1.3.3 Specific Conformance to Basic Image Box SOP Class

Table 3.2.3-12 - Basic Image Box SOP Class: Supported DIMSE operations

Name	Description
N-SET	Updates an image box in a previously created film box.

Table 3.2.3-13 - Basic Image Box SOP Class: Supported Attributes

Attribute Name	Tag	Supported Values	Default Value
Image Position	(2020,0010)	1	
Polarity	(2020,0020)	NORMAL REVERSE	
Preformatted Grayscale Image Sequence	(2020,0110)		
> Samples Per Pixel	(0028,0002)	1	
> Photometric Interpretation	(0028,0004)	MONOCHROME1 MONOCHROME2	
> Rows	(0028,0010)	Up to 4096	Depends on image size
> Columns	(0028,0011)	Up to 3328 (some supported test patterns are 3584)	Depends on image size
> Pixel Aspect Ratio	(0028,0034)	1\1	
> Bits Allocated	(0028,0100)	16	

Attribute Name	Tag	Supported Values	Default Value
> Bits Stored	(0028,0101)	12	
> High Bit	(0028,0102)	11	
> Pixel Representation	(0028,0103)	0000	
> Pixel Data	(7FE0,0010)		
Magnification Type	(2010,0060)	REPLICATE BILINEAR CUBIC NONE	Configured per printer. Overrides corresponding Film Box attribute.
Smoothing Type	(2010,0080)	(Configurable)	Configured per printer. Sent only if Magnification Type is CUBIC. Overrides corresponding Film Box attribute.
Requested Image Size	(2020,0030)		Indicates required row size (true size) in mm.

The behavior of Print Client AE when encountering status codes in a N-SET response is summarized in the Table below:

*Table 3.2.3-14
IMAGE BOX SOP CLASS N-SET RESPONSE STATUS HANDLING BEHAVIOR*

Service Status	Further Meaning	Error Code	Behavior
Success	Success	0000	The SCP has completed the operation successfully. Proceed to next step.
Failure	Any	Any	AWS Aborts association. Error message to user indicates "A DICOM DIMSE error was returned in a response." Specific status information is logged.

3.2.3.3.1.3.4 Specific Conformance to Printer SOP Class

Table 3.2.3-15 - Printer SOP Class: Supported DIMSE operations

Name	Description
N-EVENT-REPORT	Receives status notification.
N-GET	Retrieves an instance of a physical printer.

The Print Client displays descriptive text corresponding to Printer Status Info (2110,0020) attribute values received from a remote print AE using the N-GET operation, or received via N-EVENT-REPORT. The displayed text is based on DICOM 2006 Part 3, C.13.9.1. When the remote print AE sends a Printer Status Info value that is not recognized, the Print Client displays the Printer Status Info value directly.

The behavior of Print Client AE when encountering status codes in a N-GET response is summarized in the Table below:

*Table 3.2.3-16
PRINTER SOP CLASS N-GET RESPONSE STATUS HANDLING BEHAVIOR*

Service Status	Further Meaning	Error Code	Behavior
Success	Success	0000	The SCP has completed the operation successfully. Proceed to next step.
Failure	Any	Any	AWS Aborts association. Error message to user indicates "A DICOM DIMSE error was returned in a response." Specific status information is logged.

3.2.3.3.1.3.6 Specific Conformance to Print Job SOP Class

Table 3.2.3-17 - Print Job SOP Class: Supported DIMSE operations

Name	Description
N-EVENT-REPORT	Receives status notification.
N-GET	Retrieves an instance of an existing print job.

The Print Client displays descriptive text corresponding to Execution Status Info (2100,0030) attribute values received from a remote print AE using the N-GET operation, or received via N-EVENT-REPORT. The displayed text is based on DICOM 2006 Part 3, C.13.9.1. When the remote print AE sends an Execution Status Info value that is not recognized, the Print Client displays the Execution Status Info value directly.

The behavior of Print Client AE when encountering status codes in a N-GET response is summarized in the Table below:

*Table 3.2.3-18
PRINT JOB SOP CLASS N-GET RESPONSE STATUS HANDLING BEHAVIOR*

Service Status	Further Meaning	Error Code	Behavior
Success	Success	0000	The SCP has completed the operation successfully. Proceed to next step.
Failure	Any	Any	AWS Aborts association. Error message to user indicates "A DICOM DIMSE error was returned in a response." Specific status information is logged.

3.2.3.4 Association Acceptance Policy

The Print Client AE does not accept associations.

3.2.4 Storage Client AE

3.2.4.1 SOP Classes

This Application Entity provides Standard Conformance to the following SOP Classes:

*Table 3.2.4-1
SOP CLASSES FOR STORAGE CLIENT AE*

SOP Class Name	SOP Class UID	SCU	SCP
Digital Mammography X-Ray Image Storage – For Presentation	1.2.840.10008.5.1.4.1.1.1.2	Yes	No
Digital Mammography X-Ray Image Storage – For Processing	1.2.840.10008.5.1.4.1.1.1.2.1	Yes	No

3.2.4.2 Association Policies

3.2.4.2.1 General

The DICOM standard Application context shall be specified.

*Table 3.2.4-2
DICOM APPLICATION CONTEXT*

Application Context Name	1.2.840.10008.3.1.1.1
--------------------------	-----------------------

3.2.4.2.2 Number of Associations

Up to two associations are initiated at a time for the Storage Client AE.

3.2.4.2.3 Asynchronous Nature

The Acquisition Workstation does not support asynchronous operations (multiple outstanding transactions over a single Association).

3.2.4.2.4 Implementation Identifying Information

Table 3.2.4-3

DICOM IMPLEMENTATION CLASS AND VERSION FOR STORAGE CLIENT

Implementation Class UID	1.2.840.114089.1.0.0.2.7.6
Implementation Version Name	DCF 2.7.6b

3.2.4.3 Association Initiation Policy

3.2.4.3.1 Acquire Images / Print or Send Images

3.2.4.3.1.1 Description and Sequencing of Activities

As a default, when the user accepts an image, an internal request to transmit the image to one or more pre-selected remote storage AEs is generated. The Storage Client then attempts to establish an association with a remote storage AE and transmits the image. The Storage Client releases the association after receiving the response from the remote storage AE. This configuration allows for each image to be transmitted as soon as it is acquired and accepted, without holding associations open for extended periods of time while a procedure is being performed.

The Acquisition Workstation may also be configured to postpone transmission until the user closes a procedure, after which an internal request to transmit all of the accepted images to one or more pre-selected remote storage AEs is generated. The Storage Client then attempts to establish an association with a remote storage AE and transmits all of the images within that one association. The Storage Client releases the association after receiving the last response from the remote storage AE.

When a storage request is generated to transmit images from the Acquisition Workstation, the Storage Client establishes an association with a remote storage AE, requesting either the Digital Mammography X-Ray Image Storage (For Processing) SOP class or the Digital Mammography X-Ray Image Storage (For Presentation) SOP class. The output format is configured per remote storage AE. After the association is established a C-STORE request is made to transfer each image to the remote storage AE. The Storage Client waits for each C-STORE response to be received before sending the next C-STORE request.

3.2.4.3.1.2 Proposed Presentation Contexts

The Storage Client attempts to establish associations using the following presentation contexts:

Table 3.2.4-4

PROPOSED PRESENTATION CONTEXTS FOR ACQUIRE IMAGES

Presentation Context Table					
Abstract Syntax		Transfer Syntax		Role	Extended Negotiation
Name	UID	Name List	UID List		
Digital Mammography X-Ray Image Storage – For Presentation	1.2.840.10008.5.1.4.1.1.1.2	Implicit VR, Little Endian	1.2.840.10008.1.2	SCU	None
Digital Mammography X-Ray Image Storage – For Processing	1.2.840.10008.5.1.4.1.1.1.2.1	Implicit VR, Little Endian	1.2.840.10008.1.2	SCU	None

3.2.4.3.1.3 SOP Specific Conformance for Storage

The behavior of the Acquisition Workstation when encountering status codes in a C-STORE response is summarized in the Table below.

*Table 3.2.4-5
STORAGE C-STORE RESPONSE STATUS HANDLING BEHAVIOR*

Service Status	Further Meaning	Error Code	Behavior
Success	Success	0000	The SCP has successfully stored the SOP Instance. Proceed to next step.
Warning		B000	AWS aborts association. Error message to user indicates "A DICOM DIMSE error was returned in a response: Data element coercion"
	Data set does not match SOP Class	B007	AWS aborts association. Error message to user indicates "A DICOM DIMSE error was returned in a response: Data set does not match (warning)"
	Elements discarded	B006	AWS aborts association. Error message to user indicates "A DICOM DIMSE error was returned in a response: Elements discarded"
	Attribute list error	0107	AWS aborts association. Error message to user indicates "A DICOM DIMSE error was returned in a response: Unrecognized attribute"
Failure	Out of resources	A7xx	AWS aborts association. Error message to user indicates "A DICOM DIMSE error was returned in a response: Out of resources"
	Data set does not match SOP Class	A9xx	AWS aborts association. Error message to user indicates "A DICOM DIMSE error was returned in a response: Data set does not match (error)"
	Cannot understand	Cxxx	AWS aborts association. Error message to user indicates "A DICOM DIMSE error was returned in a response: Cannot understand"
	Class instance conflict	0119	AWS aborts association. Error message to user indicates "A DICOM DIMSE error was returned in a response: Class instance conflict"

The behavior of the Acquisition Workstation during communication failure is summarized in the Table below. Depending on the type of failure, and retry configuration, the send job may be retried several times before reporting an error to the user.

*Table 3.2.4-6
STORAGE COMMUNICATION FAILURE BEHAVIOR*

Exception	Behavior
Timeout	The Association is aborted and an error message is posted to the user: "Timeout waiting for response."
Association aborted by SCP	The error message "Unable to connect to destination host/port" is posted to the user.

Instance UIDs are globally unique for all SOP instances generated by the Acquisition Workstation. The UID root is “1.2.840.113681.”

- The Acquisition Workstation populates all Type 1 attributes with valid data and always sends them to the Remote Storage AE.
- The Acquisition Workstation sends all Type 2 attributes and populates them if valid source data are available.
- When configured the Acquisition Workstation sends Type 3, standard extended, and private attributes to the Remote Storage AE and populates them if valid source data are available.

3.2.4.4 Association Acceptance Policy

The Storage Client AE does not accept associations.

3.2.5 Storage Commitment Client AE

3.2.5.1 SOP Class

This Application Entity provides Standard Conformance to the following SOP Class:

*Table 3.2.5-1
SOP CLASS FOR STORAGE COMMITMENT CLIENT AE*

SOP Class Name	SOP Class UID	SCU	SCP
Storage Commitment Push Model	1.2.840.10008.1.20.1	Yes	No

3.2.5.2 Association Policies

3.2.5.2.1 General

The DICOM standard Application context shall be specified.

*Table 3.2.5-2
DICOM APPLICATION CONTEXT*

Application Context Name	1.2.840.10008.3.1.1.1
--------------------------	-----------------------

3.2.5.2.2 Number of Associations

One association is initiated at a time for the Storage Commitment Client AE.

3.2.5.2.3 Asynchronous Nature

The Acquisition Workstation does not support asynchronous operations (multiple outstanding transactions over a single Association).

3.2.5.2.4 Implementation Identifying Information

*Table 3.2.5-3
DICOM IMPLEMENTATION CLASS AND VERSION FOR STORAGE COMMITMENT CLIENT*

Implementation Class UID	1.2.840.114089.1.0.0.2.7.6
Implementation Version Name	DCF 2.7.6b

3.2.5.3 Association Initiation Policy

3.2.5.3.1 Commit Images

3.2.5.3.1.1 Description and Sequencing of Activities

When the Storage Commitment Client is configured it attempts to establish an association with a remote storage commitment AE after the Storage Client receives successful C-STORE responses for one or more images. When an association is established, a N-ACTION request is sent to request storage commitment for previously stored images. The Storage Commitment Client releases the association immediately after receiving the N-ACTION response from the remote storage commitment AE.

3.2.5.3.1.2 Proposed Presentation Contexts

The Storage Commitment Client attempts to establish associations using the following presentation contexts:

*Table 3.2.5-4
PROPOSED PRESENTATION CONTEXTS FOR COMMIT IMAGES*

Presentation Context Table					
Abstract Syntax		Transfer Syntax		Role	Extended Negotiation
Name	UID	Name List	UID List		
Storage Commitment Push Model	1.2.840.10008.1.20.1	Implicit VR, Little Endian	1.2.840.10008.1.2	SCU	None

3.2.5.3.1.3 SOP Specific Conformance for Storage Commitment

The behavior of the Acquisition Workstation when encountering status codes in a Storage Commitment N-ACTION response is summarized in the Table below.

*Table 3.2.5-5
STORAGE COMMITMENT N-ACTION RESPONSE STATUS HANDLING BEHAVIOR*

Service Status	Further Meaning	Error Code	Behavior
Success	Success	0000	The request for storage comment is considered successfully sent. The commit status of each image is set to REQUESTED.
Warning	Attribute value out of range	0106	AWS aborts association. Error message to user indicates: "A DICOM DIMSE error was returned in a response. Storage Commit job failed."
Failure	Unrecognized operation	0211	AWS aborts association. Error message to user indicates: "A DICOM DIMSE error was returned in a response. Storage commit job failed."

The behavior of the Acquisition Workstation during communication failure is summarized in the Table below. Depending on the type of failure, and retry configuration, the commit job request may be retried several times before reporting an error to the user.

*Table 3.2.5-6
STORAGE COMMITMENT COMMUNICATION FAILURE BEHAVIOR*

Exception	Behavior
Timeout	The Association is aborted and an error message if posted to the user: "Storage Commit job was not acknowledged in the allotted time. Status of commit job is unknown."
Association aborted by SCP	The error message "Cannot open socket to specified host/port, a network error has occurred, or received abort from remote system" is posted to the user.

The Storage Commitment Client supports the following N-ACTION attributes:

Table 3.2.5-7 - Supported Storage Commitment N-ACTION Attributes

Action Type Name	Action Type ID	Attribute	Tag	Notes
Request Storage Commitment	1	Transaction UID	(0008,1195)	Acquisition Workstation generates
		Referenced SOP Sequence	(0008,1199)	Acquisition Workstation generates, one or more Items
		> Referenced SOP Class UID	(0008,1150)	1.2.840.10008.5.1.4.1.1.1.2 or 1.2.840.10008.5.1.4.1.1.1.2.1
		> Referenced SOP Instance UID	(0008,1155)	Instance UID of image to be committed

3.2.5.4 Association Acceptance Policy

3.2.5.4.1 Activity – Receive Storage Commitment Response

3.2.5.4.1.1 Description and Sequencing of Activities

The Storage Commitment Client AE will accept associations in order to receive responses to a Storage Commitment Request.

The Storage Commitment Client AE accepts a reverse role association request from a remote storage commitment AE using the Storage Commitment Push Model SOP Class. After accepting an association an N-EVENT-REPORT request is expected that provides the status of a previous request for storage commitment of an image. The Storage Commitment Client AE waits for a configurable period of time, and if a N-EVENT-REPORT request is not received, the association is aborted.

The Transaction UID value in a received N-EVENT-REPORT request is checked. SOP Instances UIDs that are successfully committed are checked and recorded. SOP Instances UIDs that are not committed are logged.

3.2.5.4.1.2 Accepted Presentation Contexts

*Table 3.2.5-8
ACCEPTABLE PRESENTATION CONTEXTS FOR
STORAGE COMMITMENT CLIENT AND RECEIVE STORAGE COMMITMENT RESPONSE*

Presentation Context Table					
Abstract Syntax		Transfer Syntax		Role	Extended Negotiation
Name	UID	Name	UID		
Storage Commitment Push Model	1.2.840.10008.1.20.1	Implicit VR, Little Endian	1.2.840.10008.1.2	SCU	None

3.2.5.4.1.3 SOP Specific Conformance for Storage Commitment

Upon receipt of a N-EVENT-REPORT request, the commit status of the referenced images is updated, and a N-EVENT-REPORT response is sent.

The behavior of Storage Commitment Client AE when receiving Event Types within the N-EVENT-REPORT is summarized in the Table below.

*Table 3.2.5-9
STORAGE COMMITMENT N-EVENT-REPORT BEHAVIOR*

Event Type Name	Event Type ID	Behavior
Storage Commitment Request Successful	1	The commit status of the Referenced SOP Instances under Referenced SOP Sequence (0008,1199) is set to ACKNOWLEDGED. Successfully committed SOP Instances are candidates for automatic deletion from the local database if local resources become scarce, unless they are otherwise protected from deletion. The conditions under which automatic deletion is initiated and the amount of space freed are site configurable.
Storage Commitment Request Complete – Failures Exist	2	The Referenced SOP Instances under Referenced SOP Sequence (0008, 1199) are treated in the same way as in the success case (Event Type 1). A message is logged for each of the Referenced SOP Instances under Failed SOP Sequence (0008,1198).

The reasons for returning specific status codes in a N-EVENT-REPORT response are summarized in the Table below.

*Table 3.2.5-10
STORAGE COMMITMENT N-EVENT-REPORT RESPONSE STATUS*

Service Status	Further Meaning	Error Code	Reason
Success	Success	0000	

3.2.6 Query/Retrieve Client AE

3.2.6.1 SOP Classes

This Application Entity provides Standard Conformance to the following SOP Classes:

*Table 3.2.6-1
SOP CLASSES FOR QUERY/RETRIEVE CLIENT AE*

SOP Class Name	SOP Class UID	SCU	SCP
Study Root Query/Retrieve Information Model – FIND	1.2.840.10008.5.1.4.1.2.2.1	Yes	No
Study Root Query/Retrieve Information Model – MOVE	1.2.840.10008.5.1.4.1.2.2.2	Yes	No

3.2.6.2 Association Policies

3.2.6.2.1 General

The DICOM standard Application context shall be specified.

*Table 3.2.6-2
DICOM APPLICATION CONTEXT*

Application Context Name	1.2.840.10008.3.1.1.1
--------------------------	-----------------------

3.2.6.2.2 Number of Associations

One association is initiated at a time for the Query/Retrieve Client AE.

3.2.6.2.3 Asynchronous Nature

The Acquisition Workstation does not support asynchronous operations (multiple outstanding transactions over a single Association).

3.2.6.2.4 Implementation Identifying Information

**Table 3.2.6-3
DICOM IMPLEMENTATION CLASS AND VERSION FOR QUERY/RETRIEVE CLIENT**

Implementation Class UID	1.2.840.114089.1.0.0.2.7.6
Implementation Version Name	DCF 2.7.6b

3.2.6.3 Association Initiation Policy

3.2.6.3.1 Retrieve Prior Images

3.2.6.3.1.1 Description and Sequencing of Activities

The Query/Retrieve Client allows the user to enter matching keys that are used to query the remote Query/Retrieve AE using C-FIND operation. The Query/Retrieve Client then displays a list of patients returned in the C-FIND response. The user may select a patient from the list, which signals the Query/Retrieve Client to generate a C-MOVE request to the remote Query/Retrieve AE. The image data received is made available for the user to view on the Acquisition Workstation. The Query/Retrieve Client can be configured to post an alarm to the user when the C-MOVE operation fails or completes successfully.

The Query/Retrieve Client attempts to establish an association with a remote Query/Retrieve AE when an internal request to transmit a C-FIND or C-MOVE to a given remote Query/Retrieve AE is received. The Query/Retrieve Client releases the association after receiving the final C-FIND or C-MOVE response from the remote Query/Retrieve AE.

3.2.6.3.1.2 Proposed Presentation Contexts

The Query/Retrieve Client attempts to establish associations using the following presentation contexts:

*Table 3.2.6-4
PROPOSED PRESENTATION CONTEXTS FOR RETRIEVE PRIOR IMAGES*

Presentation Context Table					
Abstract Syntax		Transfer Syntax		Role	Extended Negotiation
Name	UID	Name List	UID List		
Study Root Query/Retrieve Information Model – FIND	1.2.840.10008.5.1.4.1.2.2 .1	Implicit VR, Little Endian	1.2.840.10008.1.2	SCU	None
Study Root Query/Retrieve Information Model – MOVE	1.2.840.10008.5.1.4.1.2.2 .2	Implicit VR, Little Endian	1.2.840.10008.1.2	SCU	None

3.2.6.3.1.3 SOP Specific Conformance for Query/Retrieve

The behavior of the Acquisition Workstation when encountering status codes in a C-FIND or C-MOVE response is summarized in the Table below.

*Table 3.2.6-5
C-FIND AND C-MOVE RESPONSE STATUS HANDLING BEHAVIOR*

Service Status	Further Meaning	Error Code	Behavior
Success	Matching or sub-operations are complete	0000	The SCP has successfully returned all matching information, or sub-operations are complete. For C-FIND, perform follow-up query or display results to the user.
Pending	Matches or sub-operations are continuing	FF00	For C-FIND, the matching query result contained in the Identifier is collected for later display.
Warning or Failure	Any	Any	AWS aborts association. Error message to the user indicates the Query Response Status error code, error comment, and DIMSE Status description.

The behavior of the Acquisition Workstation during communication failure is summarized in the Table below.

*Table 3.2.6-6
C-FIND AND C-MOVE COMMUNICATION FAILURE BEHAVIOR*

Exception	Behavior
Timeout	The Association is aborted and an error message is posted to the user: "Query/Retrieve not acknowledged in the allotted time."
Association aborted by SCP	The Association is aborted and any C-FIND results received before this occurs are displayed to the user. For C-MOVE, an error is indicated: "There were error(s) when pulling back the image(s): Cannot open socket to specified host/port, a network error has occurred, or received abort from remote system."

The Query/Retrieve Client provides standard conformance to the Study Root Information Model. When the hierarchical method is configured, a Study level query is sent, and the responses are used to send follow-up Series level queries automatically. For retrieve, a Study level move request is sent, containing the Study Instance UID of the study to retrieve. When the relational method is configured, one Study level query is sent. The relational method is not used for retrieve.

The Query/Retrieve Client supports default query Matching Key Attributes as defined in the following table. The Matching Key Attributes are contained in configuration files per Query/Retrieve provider, and can be modified as required for compatibility with remote Query/Retrieve AEs. The user supplies Matching Key Attribute values other than Modality, either by manual entry or date range selection.

Table 3.2.6-7 - Supported C-FIND Matching Key Attributes (Hierarchical)

Matching Key Attribute	Tag	Matching Type
Study Level		
Patient's Name	(0010,0010)	Wild Card Matching
Patient ID	(0010,0020)	Single Value or Wild Card Matching
Study Date	(0008,0020)	Single Value or Range Matching
Study Time	(0008,0030)	Universal Matching
Accession Number	(0008,0050)	Universal Matching
Study ID	(0020,0010)	Universal Matching
Study Instance UID	(0020,000D)	Universal Matching
Series Level		
Study Instance UID	(0020,000D)	Single Value Matching (from Study level result)
Series Number	(0020,0011)	Universal Matching
Series Instance UID	(0020,000E)	Universal Matching
Modality	(0008,0060)	Single Value or Wild Card Matching (MG)

Table 3.2.6-8 - Supported C-FIND Matching Key Attributes (Relational)

Matching Key Attribute	Tag	Matching Type
Patient's Name	(0010,0010)	Wild Card Matching
Patient ID	(0010,0020)	Single Value or Wild Card Matching
Study Date	(0008,0020)	Single Value or Range Matching
Study Time	(0008,0030)	Universal Matching
Accession Number	(0008,0050)	Universal Matching
Study ID	(0020,0010)	Universal Matching
Study Instance UID	(0020,000D)	Universal Matching
Modality	(0008,0060)	Single Value or Wild Card Matching (MG)

3.2.6.4 Association Acceptance Policy

The Query/Retrieve Client AE does not accept associations.

3.2.7 Storage Server AE

3.2.7.1 SOP Classes

This Application Entity provides Standard Conformance to the following SOP Classes:

*Table 3.2.7-1
SOP CLASSES FOR STORAGE SERVER AE*

SOP Class Name	SOP Class UID	SCU	SCP
Digital Mammography X-Ray Image Storage – For Presentation	1.2.840.10008.5.1.4.1.1.1.2	No	Yes
Digital Mammography X-Ray Image Storage – For Processing	1.2.840.10008.5.1.4.1.1.1.2.1	No	Yes

3.2.7.2 Association Policies

3.2.7.2.1 General

The DICOM standard Application context shall be specified.

*Table 3.2.7-2
DICOM APPLICATION CONTEXT*

Application Context Name	1.2.840.10008.3.1.1.1
--------------------------	-----------------------

3.2.7.2.2 Number of Associations

One association is accepted at a time for the Storage Server AE.

3.2.7.2.3 Asynchronous Nature

The Acquisition Workstation does not support asynchronous operations (multiple outstanding transactions over a single Association).

3.2.7.2.4 Implementation Identifying Information

*Table 3.2.7-3
DICOM IMPLEMENTATION CLASS AND VERSION FOR STORAGE SERVER*

Implementation Class UID	1.2.840.114089.1.0.0.2.7.6
Implementation Version Name	DCF 2.7.6b

3.2.7.3 Association Initiation Policy

The Storage Server AE does not initiate associations.

3.2.7.4 Association Acceptance Policy

When the Storage Server AE accepts an association, it will respond to storage requests.

3.2.7.4.1 Activity – Receive Prior Images

3.2.7.4.1.1 Description and Sequencing of Activities

The Storage Server AE is triggered to start when the Query/Retrieve Client AE sends a retrieve request. The Storage Server AE stores the images received so that they can be made available to the user. The Storage Server AE stops running when the Query/Retrieve Client AE receives a C-MOVE response of success or failure. If a received instance is a duplicate of an existing stored instance, the received instance is ignored, and the user is alerted that a duplicate was received.

3.2.7.4.1.2 Accepted Presentation Contexts

The Storage Server accepts associations using the following presentation contexts:

*Table 3.2.7-4
ACCEPTABLE PRESENTATION CONTEXTS FOR
STORAGE SERVER AND RECEIVE PRIOR IMAGES*

Presentation Context Table					
Abstract Syntax		Transfer Syntax		Role	Extended Negotiation
Name	UID	Name	UID		
Digital Mammography X-Ray Image Storage – For Presentation	1.2.840.10008.5.1.4.1.1.1.2	Implicit VR, Little Endian	1.2.840.10008.1.2	SCP	None
Digital Mammography X-Ray Image Storage – For Processing	1.2.840.10008.5.1.4.1.1.1.2.1	Implicit VR, Little Endian	1.2.840.10008.1.2	SCP	None

3.2.7.4.1.3 SOP Specific Conformance for Storage SOP Classes

The Storage Server AE provides standard conformance to the Storage Service Class.

The Storage Server AE will behave as described in the Table below when generating the C-STORE response.

*Table 3.2.7-5
STORAGE C-STORE RESPONSE STATUS*

Service Status	Further Meaning	Error Code	Reason
Success	Success	0000	Image is stored locally and made available to the user.
Failure	Refused: Out of Resources	A7xx	There is not enough local storage capacity to store the image. Error Comment (0000,0902) is sent.
	Processing failure	0110	Any other failure. Error Comment (0000,0902) is sent containing explanation.

3.2.8 Verification SCP

3.2.8.1 SOP Classes

This Application Entity provides Standard Conformance to the following SOP Class:

*Table 3.2.8-1
SOP CLASS FOR VERIFICATION SCP AE*

SOP Class Name	SOP Class UID	SCU	SCP
Verification SOP Class	1.2.840.10008.1.1	No	Yes

3.2.8.2 Association Policies

3.2.8.2.1 General

The DICOM standard Application context shall be specified.

*Table 3.2.8-2
DICOM APPLICATION CONTEXT*

Application Context Name	1.2.840.10008.3.1.1.1
--------------------------	-----------------------

3.2.8.2.2 Number of Associations

One association is accepted at a time for the Verification SCP AE.

3.2.8.2.3 Asynchronous Nature

The Acquisition Workstation does not support asynchronous operations (multiple outstanding transactions over a single Association).

3.2.8.2.4 Implementation Identifying Information

*Table 3.2.8-3
DICOM IMPLEMENTATION CLASS AND VERSION FOR VERIFICATION SCP*

Implementation Class UID	1.2.840.114089.1.0.0.2.7.6
Implementation Version Name	DCF 2.7.6b

3.2.8.3 Association Initiation Policy

The Verification SCP AE does not initiate associations.

3.2.8.4 Association Acceptance Policy

3.2.8.4.1 Activity – Receive Echo Request

3.2.8.4.1.1 Description and Sequencing of Activities

The Verification SCP is available only as a service tool, and is running when the Echo SCP package is installed.

3.2.8.4.1.2 Accepted Presentation Contexts

The Verification SCP accepts associations using the following presentation contexts:

*Table 3.2.8-4
ACCEPTABLE PRESENTATION CONTEXTS FOR
VERIFICATION SCP AND RECEIVE ECHO REQUEST*

Presentation Context Table					
Abstract Syntax		Transfer Syntax		Role	Extended Negotiation
Name	UID	Name	UID		
Verification SOP Class	1.2.840.10008.1.1	Implicit VR, Little Endian	1.2.840.10008.1.2	SCP	None

3.2.8.4.1.3 SOP Specific Conformance for Verification SOP Class

Verification SCP provides standard conformance to the Verification Service Class.

3.3. Network Interfaces

3.3.1 Physical Network Interface

The Acquisition Workstation is tested and supports using 10-BaseT, 100-BaseT, and 1000-BaseT Ethernet media.

3.3.2 Additional Protocols

None.

3.4. Configuration

The DICOM Query/Retrieve, Storage, Storage Commitment, Print, Modality Performed Procedure Step and Modality Worklist Clients are configured during site installation.

A Verification Client, used primarily as a troubleshooting tool, is made available through a service tool utility. It attempts to establish an association with a remote Verification SCP when invoked by a service tool utility from the command line. It requests one presentation context, the Verification SOP Class with the DICOM default transfer syntax. A message listing all available parameters may be obtained by invoking the command without specifying parameters.

3.4.1 AE Title/Presentation Address Mapping

3.4.1.1 Local AE Titles

*Table 3.4-1
AE TITLE CONFIGURATION TABLE*

Application Entity	Default AE Title	Default TCP/IP Port
Storage Client	DIRECT_DIGXRAY	N/A
Print Client	DIRECT_DIGXRAY	N/A
Modality Worklist Client	DIRECT_DIGXRAY	N/A
Modality PPS Client	DIRECT_DIGXRAY	N/A
Storage Commitment Client	DIRECT_DIGXRAY	2400
Query/Retrieve Client	DIRECT_DIGXRAY	N/A
Local Storage Server	DIRECT_DIGXRAY	7400

The default AE Title and TCP/IP Port number may be modified. The port number must be greater than 1023.

3.4.1.2 Remote AE Title/Presentation Address Mapping

Up to 64 Remote Storage or Print SCPs can be configured.

3.4.1.2.1 Remote Modality Worklist SCP

The following are some of the relevant configurable items for the Remote Modality Worklist SCP:

Table 3.4-2 –Remote Modality Worklist SCP Configuration

Parameter description	Range
Application Entity Title (Called AE)	The Acquisition Workstation supports one AE acting as a Modality Worklist provider.
Remote Host/IP Address	IP address and hostname associated with the Modality Worklist provider AE.
Remote Port Number	Port number to use when establishing TCP/IP connection to the Modality Worklist provider AE. Range = 1 to 65,535

3.4.1.2.2 Remote MPPS SCP

The following are some of the relevant configurable items for the Remote MPPS SCP:

Table 3.4-3 –Remote MPPS SCP Configuration

Parameter description	Range
Application Entity Title (Called AE)	The Acquisition Workstation supports one AE acting as a MPPS provider.
Remote Host/IP Address	IP address and hostname associated with the MPPS provider AE.
Remote Port Number	Port number to use when establishing TCP/IP connection to the MPPS provider AE. Range = 1 to 65,535

3.4.1.2.3 Remote Print SCP

The following are some of the relevant configurable items for each Remote Print SCP:

Table 3.4-4 – Remote Print SCP Configuration

Parameter Description	Range
Application Entity Title (Called AE)	The Acquisition Workstation supports multiple AEs acting as Remote Print SCP.
Remote Host/IP Address	IP address and hostname, one per Remote Print AE.
Remote Port Number	Port number to use when establishing TCP/IP connection, one per Remote Print AE. Range = 1 to 65,535
Send from Image Acquisition	Send immediate (after each image is acquired and accepted), or wait until the procedure is closed to send all acquired and accepted images. One setting per Remote Print AE.

3.4.1.2.4 Remote Storage SCP

The following are some of the relevant configurable items for each Remote Storage SCP:

Table 3.4-5 – Remote Storage SCP Configuration

Parameter Description	Range
Application Entity Title (Called AE)	The Acquisition Workstation supports multiple AEs acting as Remote Storage SCP.
Remote Host/IP Address	IP address and hostname, one per Remote Storage AE.
Remote Port Number	Port number to use when establishing TCP/IP connection, one per Remote Storage AE. Range = 1 to 65,535
Store IOD	Digital Mammography X-Ray Image Storage - For Processing or Digital Mammography X-Ray Image Storage – For Presentation
Storage Commitment	Enabled or disabled
Send from Image Acquisition	Send immediate (after each image is acquired and accepted), or wait until the procedure is closed to send all acquired and accepted images. One setting per remote storage AE.

3.4.1.2.5 Remote Storage Commitment SCP

The following are some of the relevant configurable items for the Remote Storage Commitment SCP:

Table 3.4-6 –Remote Storage Commitment SCP Configuration

Parameter description	Range
Application Entity Title (Called AE)	One Remote Storage AE should be configured for storage commitment, if desired.
Remote Host/IP Address	IP address and hostname of Remote Storage Commitment AE.
Port Number	Port number to be used when establishing TCP/IP connection to the Remote Storage Commitment SCP. Range = 1 to 65,535

3.4.1.2.6 Remote Query/Retrieve SCP

The following are some of the relevant configurable items for the Remote Query/Retrieve SCP:

Table 3.4-7 –Remote Query/Retrieve SCP Configuration

Parameter description	Range
Application Entity Title (Called AE)	The Acquisition Workstation supports one AE acting as a Query/Retrieve provider.
Remote Host/IP Address	IP address and hostname associated with the Query/Retrieve provider AE.
Port Number	Port number to use when establishing TCP/IP connection to the Query/Retrieve provider AE. Range = 1 to 65,535
Query method	Hierarchical or Relational
Information Model	Study Root
Query/Retrieve Level	Study level
Query filter	Modality filter: MG (may be modified)

3.4.2 Configuration Parameters for Local AEs

The following are some of the relevant configurable items for the local AEs:

Table 3.4-8 – CONFIGURATION PARAMETERS

Parameter	Configurable (Yes/No)	Default Value
Number of seconds to wait for response to TCP/IP connect request (operating system controlled)	No	~220
ACSE PDU read timeout: Number of seconds to wait for response to an Association Open or Close Request.	Yes	30
ARTIM timeout: Number of seconds for acting SCP to wait from socket accept until Association request is read	Yes	30
Association Idle Timeout: Number of seconds of idle time allowed before an acting SCP automatically terminates an association. The idle timer runs until a complete DIMSE message is received.	Yes	180
Maximum PDU size the AE can receive	Yes, per local SCU	32,768
Maximum PDU size the AE can send (used if not negotiated). Range = 1,024 to 65,535	Yes, per local SCU	32,768
Modality Worklist Client		
Polling (On/Off)	Yes	Off
Poll period in minutes	Yes	15
MWL query timeout: Number of seconds to wait for C-FIND response	Yes	600
Maximum number of MWL items accepted	Yes	500
MWL response cache location	Yes	/tmp/Worklist
Matching Keys: Configured and mapped using attributes defined in section 3.2.1.3.1.3	Yes	
Return Keys: Configured and mapped using attributes defined in section 3.2.1.3.1.3	Yes	
RIS Code attribute	Yes	(0032,1064)
Modality PPS Client		
MPPS enabled	Yes	Disabled
Maximum retries	Yes	10
Radiation Dose option	Yes	False
Exception Management option	Yes	True
Discontinued Reasons	Yes	CID 9300 list
MPPS ACSE PDU read timeout: Number of seconds to wait for response to an Association Open or Close Request.	Yes	30
MPPS N-CREATE timeout: Number of seconds to wait for N-CREATE response	Yes	20
MPPS N-SET timeout: Number of seconds to wait for N-SET	Yes	20

Parameter	Configurable (Yes/No)	Default Value
response		
Print Client		
Response timeout: Number of seconds to wait for a response to any DIMSE-N command.	Yes	240
Association Control: The Print Client may be configured to control associations by: - Requesting the use of the Print Job SOP Class	Yes	Do not request Print Job
Print Job Timeout: Applies only when Print Job is requested. Number of seconds to allow after N-ACTION request is sent for DONE or FAILURE response from printer.	Yes	240
Print Job Poll Period: Applies only when Print Job is requested. Number of seconds to wait between sending alternating Printer and Print Job N-GET requests after receiving N-ACTION response. Range = 1 to 32,767	Yes	15
Storage Client		
Response timeout: Number of seconds to wait for a C-STORE response.	Yes	240
Storage Commitment Client		
Response timeout: Number of seconds to wait for N-ACTION response	No	180
Query/Retrieve Client		
C-FIND Timeout: Number of seconds to wait for C-FIND response.	Yes	10
C-MOVE Timeout: Number of seconds to wait for C-MOVE response	Yes	300
Date Range: Two parameters are used as the "Start Days" and "End Days".	Yes	
Minimum search name character: Minimum number of characters used as part of a query that matches on Patient's Name.	Yes	2
Minimum search id characters: Minimum number of characters used as part of a query that matches on Patient ID.	Yes	5
Max Entries: Maximum number of entries listed as a result of a query.	Yes	50
Procedure Match: Retrieve image only if a Procedure Code matches. Range = Yes, No	Yes	No
Post Alarm: Post alarm on final C-MOVE response reporting success of retrieve request. Range = Yes, No	Yes	No
Storage Server		
TCP port: Port on which the Acquisition Workstation Association Manager listens when the remote Query/Retrieve AE initiates a C-STORE based on a C-MOVE request. Range = greater than 1023	Yes	7400

4.0 Media Interchange

4.1. Implementation Model

4.1.1 Application Data Flow Diagram

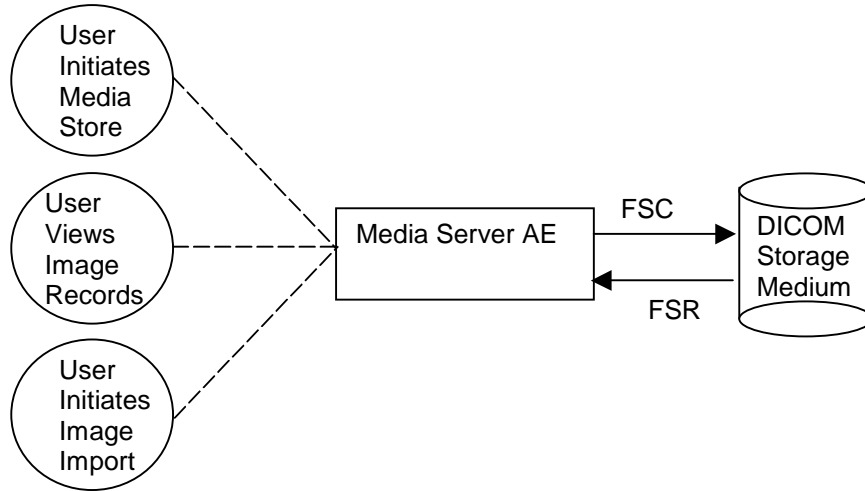

Figure 4.1-1 Application Data Flow Diagram for Media Storage

The Media Server AE provides a means to export and import Hologic Digital Mammography images using DICOM Part 10: Media Storage and File Format for Media Interchange. Images can be recorded and read via a CD-R drive. This feature is provided as a matter of convenience for users to move images from one system to another via compact disks. This feature is not intended to serve as an archive for permanently storing images.

4.1.2 Functional Definition of AEs

The Media Server AE can store images to CD-R, as well as import images that have been stored on CD-R into the Acquisition Workstation database. Three formats for image storage are available:

- DICOM Part 10 format, storing images using the Digital Mammography X-Ray Image Storage – For Processing SOP Class,
- DICOM Part 10 format, storing images using the Digital Mammography X-Ray Image Storage –For Presentation SOP Class, and
- Service utility, storing images with encrypted protected healthcare information per HIPAA guidelines.

Only the DICOM Part 10 format is defined in this document. For information on the service utility format, please refer to service documentation for the Selenia Acquisition Workstation.

The Acquisition Workstation supports DICOM Media Storage as both an FSC and FSR.

4.1.3 Sequencing of Real World Activities

The Acquisition Workstation user interface provides access to configure and use CD-R as an output device during image acquisition, or separate from image acquisition, to export acquired images to removable media.

The Acquisition Workstation user interface provides access to view the content of CD-R media that were created by a Selenia Acquisition Workstation, and to select items to import from removable media to the Acquisition Workstation.

4.1.4 File Meta Information for Implementation Class Version

The implementation information written to the File Meta Header in each file is:

*Table 4.1-1
DICOM IMPLEMENTATION CLASS AND VERSION FOR MEDIA STORAGE*

Implementation Class UID	1.2.840.114089.1.0.0.2.7.6
Implementation Version Name	DCF 2.7.6b

4.2. AE Specifications

4.2.1 Media Server AE Specification

The Media Server AE provides standard conformance to the DICOM Interchange Option of the Media Storage Service Class (SC). The Application Profiles and roles are listed below:

*Table 4.2-1
AE RELATED APPLICATION PROFILES, REAL-WORLD ACTIVITIES, AND ROLES*

Supported Application Profile	Real-World Activity	Roles	SC Option
STD-GEN-CD	User Initiates Media Store	FSC	Interchange
	User Views Image Records	FSR	Interchange
	User Initiates Image Import	FSR	Interchange

4.2.1.1 File Meta Information for Media Server AE

The Source Application Entity Title included in the File Meta Header is DCF_TEST_1.

4.2.1.2 Real-World Activities

4.2.1.2.1 Activity – User Initiates Media Store

The Media Server AE acts as an FSC using the interchange option when requested to export images to CD-R medium.

To store images to a compact disc, an output selection for CD-R must be installed and configured. The CD-R can be available as an output destination while acquiring images, or after acquiring images through the Resend or Spool Management tools under the Admin menu listing. Images can be added to any disc, provided the capacity is available to record the selected images. In addition to DICOM file format images being stored, the Media Server AE will also automatically store other files that support the importing of Acquisition Workstation data back into the system, such as thumbnail images and digital marker information.

4.2.1.2.1.1 Media Storage Application Profile

The Media Server AE supports the STD-GEN-CD Application Profile.

4.2.1.2.1.1.1 Options

The Media Server AE supports the SOP Classes and Transfer Syntaxes listed in the Table below:

*Table 4.2-2
IODS, SOP CLASSES AND TRANSFER SYNTAXES FOR MEDIA SERVER*

SOP Class Name	SOP Class UID	Transfer Syntax	Transfer Syntax UID
Media Storage Directory Storage	1.2.840.10008.1.3.10	Explicit VR Little Endian	1.2.840.10008.1.2.1
Digital Mammography X-Ray Image Storage – For Presentation	1.2.840.10008.5.1.4.1.1.1.2	Explicit VR Little Endian	1.2.840.10008.1.2.1
Digital Mammography X-Ray Image Storage – For Processing	1.2.840.10008.5.1.4.1.1.1.2.1	Explicit VR Little Endian	1.2.840.10008.1.2.1

4.2.1.2.2 Activities – User Views Image Records, User Initiates Image Import

User Views Image Records: No installation or configuration is required to view the contents of CD-R media. Using the Import tool under the Admin menu listing, the Acquisition Workstation user can view the directory of a compact disc including patient, study, series, and image information.

User Initiates Image Import: Images can be imported from CD-R to the Acquisition Workstation database without any special installation or configuration. Only images originally generated on a Selenia Acquisition Workstation can be imported into the Acquisition Workstation database. Using the Import tool under the Admin menu listing, the user can choose to import the entire disc content, all images for a particular patient, a specific study, or specific image(s). A validation utility runs as part of the import process, to ensure proper identification of the patient and study.

4.2.1.2.2.1 Media Storage Application Profile

The Media Server AE supports the STD-GEN-CD Application Profile.

4.2.1.2.2.1.1 Options

The Media Server AE supports the SOP Classes and Transfer Syntaxes listed in the Table below:

*Table 4.2-3
IODS, SOP CLASSES AND TRANSFER SYNTAXES FOR MEDIA SERVER*

SOP Class Name	SOP Class UID	Transfer Syntax	Transfer Syntax UID
Media Storage Directory Storage	1.2.840.10008.1.3.10	Explicit VR Little Endian	1.2.840.10008.1.2.1
Digital Mammography X-Ray Image Storage – For Presentation	1.2.840.10008.5.1.4.1.1.1.2	Explicit VR Little Endian	1.2.840.10008.1.2.1
Digital Mammography X-Ray Image Storage – For Processing	1.2.840.10008.5.1.4.1.1.1.2.1	Explicit VR Little Endian	1.2.840.10008.1.2.1

4.3. Augmented and Private Application Profiles

None

4.4. Media Configuration

The Media output device may be configured to store Digital Mammography X-Ray Image Storage - For Presentation or For Processing SOP Instances. The Media label, File-set ID (0004,1130), is configurable.

5.0 Support of Character Sets

The Acquisition Workstation supports the following character sets for the values of Data Elements with a VR of SH, LO, ST, PN or LT:

- Default: ISO-IR 6
- Latin Alphabet No. 1: ISO-IR 100

6.0 Security

The Selenia Acquisition Workstation does not support any specific DICOM security measures.

It is assumed that the Selenia Acquisition Workstation is used within a secured environment. It is assumed that a secured environment includes at a minimum:

- Firewall or router protections to ensure that only approved external hosts have network access to the Selenia Acquisition Workstation.
- Firewall or router protections to ensure that the Selenia Acquisition Workstation only has network access to approved external hosts and services.
- Any communication with external hosts and services outside the locally secured environment use appropriate secure network channels (e.g. such as a Virtual Private Network (VPN)).
- Other network security procedures such as automated intrusion detection may be appropriate in some environments. Additional security features may be established by the local security policy and are beyond the scope of this conformance statement.

7.0 Annexes

7.1. IOD Contents

7.1.1 Created SOP Instance(s)

Abbreviations for Presence of Value:

ALWAYS	Attribute always present with a value
ANAP	Attribute not always present
EMPTY	Attribute is sent without a value (zero length)
VNAP	Attribute value not always present (zero length if no value is present)

Abbreviations for Source:

AUTO	Attribute value is generated automatically
CONFIG	Attribute value source is a configurable parameter
MWL	Attribute value is the same as the value received using Modality Worklist
USER	Attribute value source is from User input

7.1.1.1 Digital Mammography X-Ray Image IOD

The default attributes that are contained in created SOP Instances are listed in the following tables. The attributes contained in created SOP Instances are configurable.

*Table 7.1-1
IOD OF CREATED DIGITAL MAMMOGRAPHY X-RAY IMAGE SOP INSTANCES*

IE	Module	Reference	Presence of Module
Patient	Patient	Table 7.1-2	ALWAYS
Study	General Study	Table 7.1-3	ALWAYS
	Patient Study	Table 7.1-4	ALWAYS
Series	General Series	Table 7.1-5	ALWAYS
	DX Series	Table 7.1-7	ALWAYS
	Mammography Series	Table 7.1-7	ALWAYS
Equipment	General Equipment	Table 7.1-6	ALWAYS
Image	General Image	Table 7.1-8	ALWAYS
	Image Pixel	Table 7.1-9	ALWAYS
	DX Anatomy Imaged	Table 7.1-10	ALWAYS
	DX Image	Table 7.1-11	ALWAYS
	DX Detector	Table 7.1-12	ALWAYS
	DX Positioning	Table 7.1-13	ALWAYS
	X-Ray Acquisition Dose	Table 7.1-14	ALWAYS
	X-Ray Generation	Table 7.1-15	ALWAYS
	X-Ray Filtration	Table 7.1-16	ALWAYS
	X-Ray Grid	Table 7.1-17	ALWAYS
	Mammography Image	Table 7.1-18	ALWAYS
	VOI LUT	See DX Image	
	Acquisition Context	Table 7.1-19	ALWAYS
	SOP Common	Table 7.1-20	ALWAYS

7.1.1.2 Common Modules

Table 7.1-2 Patient Module of Created SOP Instances

Attribute Name	Tag	Value	Presence of Value	Source
Patient's Name	(0010,0010)		ALWAYS	MWL/USER
Patient ID	(0010,0020)		ALWAYS	MWL/USER
Patient Birth Date	(0010,0030)		ALWAYS	MWL/USER
Patient's Birth Time	(0010,0032)		VNAP	MWL
Patient Sex	(0010,0040)		VNAP	MWL/USER
Other Patient IDs	(0010,1000)		VNAP	MWL
Other Patient Names	(0010,1001)		VNAP	AUTO
Ethnic Group	(0010,2160)		VNAP	AUTO
Patient Comments	(0010,4000)		VNAP	MWL

Table 7.1-3 General Study Module of Created SOP Instances

Attribute Name	Tag	Value	Presence of Value	Source
Study Date	(0008,0020)		ALWAYS	AUTO
Study Time	(0008,0030)		ALWAYS	AUTO
Accession Number	(0008,0050)		VNAP	MWL/USER
Referring Physician's Name	(0008,0090)		VNAP	MWL/USER
Study Description	(0008,1030)		ALWAYS	MWL/AUTO
Physician(s) of Record	(0008,1048)		VNAP	MWL
Name of Physician(s) reading study	(0008,1060)		VNAP	MWL
Referenced Study Sequence	(0008,1110)		VNAP	MWL
> Referenced SOP class UID	(0008,1150)			
> Referenced SOP Instance UID	(0008,1155)			
Study Instance UID	(0020,000D)		ALWAYS	MWL/AUTO
Study ID	(0020,0010)		ALWAYS	MWL/AUTO
Procedure Code Sequence	(0008,1032)	One item if MPPS enabled	ANAP	MWL/AUTO
> Code Value	(0008,0100)			
> Coding Scheme Designator	(0008,0102)			
> Code Meaning	(0008,0104)			

Table 7.1-4 Patient Study Module of Created SOP Instances

Attribute Name	Tag	Value	Presence of Value	Source
Admitting Diagnoses Description	(0008,1080)		VNAP	MWL
Patient's Age	(0010,1010)	Calculated from (0010,0030)	ALWAYS	AUTO
Additional Patient History	(0010,21B0)		VNAP	MWL

Table 7.1-5 General Series Module of Created SOP Instances

Attribute Name	Tag	Value	Presence of Value	Source
Modality	(0008,0060)	See Table 7.1-7		
Series Instance UID	(0020,000E)	Unique value generated by AWS	ALWAYS	AUTO
Series Number	(0020,0011)	Note: every acquired image is assigned to a different DICOM Series	ALWAYS	AUTO
Series Date	(0008,0021)		ALWAYS	AUTO
Series Time	(0008,0031)		ALWAYS	AUTO
Protocol Name	(0018,1030)	Laterality and projection view	ALWAYS	AUTO
Series Description	(0008,103E)	Same as (0018,1030)	ALWAYS	AUTO
Operator's Name	(0008,1070)		ALWAYS	AUTO
Body Part Examined	(0018,0015)	BREAST	ALWAYS	AUTO
Request Attributes Sequence	(0040,0275)	Present only for image objects resulting from scheduled procedure steps	ANAP	AUTO
> Requested Procedure ID	(0040,1001)		ANAP	MWL
> Scheduled Procedure Step ID	(0040,0009)		ANAP	MWL
> Scheduled Procedure Step Description	(0040,0007)		ANAP	MWL
> Scheduled Protocol Code Sequence	(0040,0008)		ANAP	MWL

Attribute Name	Tag	Value	Presence of Value	Source
>> Code Value	(0008,0100)			
>> Coding Scheme Designator	(0008,0102)			
>> Code Meaning	(0008,0104)			
Performed Procedure Step ID	(0040,0253)		ALWAYS	AUTO
Performed Procedure Step Start Date	(0040,0244)	Date first image acquired	ALWAYS	AUTO
Performed Procedure Step Start Time	(0040,0245)	Time first image acquired	ALWAYS	AUTO
Performed Procedure Step Description	(0040,0254)		ALWAYS	AUTO
Performed Protocol Code Sequence	(0040,0260)		ANAP	AUTO
> Code Value	(0008,0100)			
> Coding Scheme Designator	(0008,0102)			
> Code Meaning	(0008,0104)			

Table 7.1-6 General Equipment Module of Created SOP Instances

Attribute Name	Tag	Value	Presence of Value	Source
Manufacturer	(0008,0070)	HOLOGIC, Inc.	ALWAYS	CONFIG
Institution Name	(0008,0080)		ALWAYS	CONFIG
Institution Address	(0008,0081)		ALWAYS	CONFIG
Station Name	(0008,1010)	Hostname	ALWAYS	AUTO
Manufacturer's Model Name	(0008,1090)	Lorad Selenia	ALWAYS	CONFIG
Device Serial Number	(0018,1000)		ALWAYS	AUTO
Software Versions	(0018,1020)		ALWAYS	AUTO
Date of Last Calibration	(0018,1200)		ALWAYS	AUTO
Time of Last Calibration	(0018,1201)		ALWAYS	AUTO
Pixel Padding Value	(0028,0120)	0	ALWAYS	AUTO

7.1.1.3 Digital Mammography X-Ray Image Modules

Table 7.1-7 DX Series / Mammography Series Module of Created SOP Instances

Attribute Name	Tag	Value	Presence of Value	Source
Modality	(0008,0060)	MG	ALWAYS	AUTO
Presentation Intent Type	(0008,0068)	Original image: "FOR PROCESSING" Derived image: "FOR PRESENTATION"	ALWAYS	AUTO
Referenced Performed Procedure Step Sequence	(0008,1111)	One Item if MPPS enabled	ANAP	AUTO
>Referenced SOP Class UID	(0008,1150)	MPPS SOP Class UID		
>Referenced SOP Instance UID	(0008,1155)			

Table 7.1-8 General Image Module of Created SOP Instances

Attribute Name	Tag	Value	Presence of Value	Source
Instance Number	(0020,0013)		ALWAYS	AUTO
Patient Orientation	(0020,0020)	See Table 7.1-11		
Content Date	(0008,0023)	Same as Acquisition Date (0008,0022)	ALWAYS	AUTO
Content Time	(0008,0033)	Same as Acquisition Time (0008,0032)	ALWAYS	AUTO
Image Type	(0008,0008)	See Table 7.1-11		
Acquisition Number	(0020,0012)		VNAP	
Acquisition Date	(0008,0022)		ALWAYS	AUTO
Acquisition Time	(0008,0032)		ALWAYS	AUTO
Derivation Description	(0008,2111)	See Table 7.1-11		
Source Image Sequence	(0008,2112)	Original image: references original image if re- viewed and saved Derived image: references the FOR PROCESSING image, plus references previous image if re- viewed and saved	ANAP	AUTO
> Referenced SOP Class UID	(0008,1150)			
> Referenced SOP Instance UID	(0008,1155)			
>Spatial Locations Preserved	(0028,135A)	YES	ALWAYS	AUTO
Images in Acquisition	(0020,1002)	1	ALWAYS	AUTO
Image Comments	(0020,4000)	User enters manually or selects from list	VNAP	USER
Burned in Annotation	(0028,0301)	See Table 7.1-11		
Lossy Image Compression	(0028,2110)	See Table 7.1-11		

Table 7.1-9 Image Pixel Module of Created SOP Instances

Attribute Name	Tag	Value	Presence of Value	Source
Samples per Pixel	(0028,0002)	See Table 7.1-11		
Photometric Interpretation	(0028,0004)	See Table 7.1-11		
Rows	(0028,0010)		ALWAYS	AUTO
Columns	(0028,0011)		ALWAYS	AUTO
Bits Allocated	(0028,0100)	See Table 7.1-11		
Bits Stored	(0028,0101)	See Table 7.1-11		
High Bit	(0028,0102)	See Table 7.1-11		
Pixel Representation	(0028,0103)	See Table 7.1-11		
Pixel Data	(7FE0,0010)		ALWAYS	AUTO
Pixel Aspect Ratio	(0028,0034)	180\180	ALWAYS	AUTO

Table 7.1-10 DX Anatomy Imaged Module of Created SOP Instances

Attribute Name	Tag	Value	Presence of Value	Source
The supported attributes are overridden by the Mammography Image module. See Table 7.1-18.				

Table 7.1-11 DX Image Module of Created SOP Instances

Attribute Name	Tag	Value	Presence of Value	Source
Image Type	(0008,0008)	Original image: ORIGINAL\PRIMARY Derived image: DERIVED\SECONDARY	ALWAYS	AUTO
Samples per Pixel	(0028,0002)	1	ALWAYS	AUTO
Photometric Interpretation	(0028,0004)	Original image: MONOCHROME1 (Minimum pixels = white) Derived image: MONOCHROME2 (Minimum pixels = black)	ALWAYS	AUTO
Bits Allocated	(0028,0100)	16	ALWAYS	AUTO
Bits Stored	(0028,0101)	Original image: 14 Derived image: 12	ALWAYS	AUTO
High Bit	(0028,0102)	Original image: 13 Derived image: 11	ALWAYS	AUTO
Pixel Representation	(0028,0103)	0000H	ALWAYS	AUTO
Pixel Intensity Relationship	(0028,1040)	Original image: LIN Derived image: LOG	ALWAYS	AUTO
Pixel Intensity Relationship Sign	(0028,1041)	Original image: 1 Derived image: -1	ALWAYS	AUTO
Rescale Intercept	(0028,1052)	0	ALWAYS	AUTO
Rescale Slope	(0028,1053)	1	ALWAYS	AUTO
Rescale Type	(0028,1054)	US	ALWAYS	AUTO
Presentation LUT Shape	(2050,0020)	Original image: INVERSE Derived image: IDENTITY	ALWAYS	AUTO
Lossy Image Compression	(0028,2110)	00	ALWAYS	AUTO
Derivation Description	(0008,2111)	Original image: zero length Derived image: Description of the image processing applied, e.g. LORAD IP + sw version of IP	VNAP	AUTO
Acquisition Device Processing Description	(0018,1400)	Original: zero length	VNAP	AUTO
Acquisition Device Processing Code	(0018,1401)	Original: zero length	VNAP	AUTO
Patient Orientation	(0020,0020)		ALWAYS	AUTO, USER
Calibration Image	(0050,0004)	NO (calibration images are not stored)	ALWAYS	AUTO
Burned in Annotation	(0028,0301)	NO	ALWAYS	AUTO
Window Center	(0028,1050)	2047	ALWAYS	AUTO
Window Width	(0028,1051)	4096	ALWAYS	AUTO

Table 7.1-12 DX Detector Module of Created SOP Instances

Attribute Name	Tag	Value	Presence of Value	Source
Detector Type	(0018,7004)	DIRECT	ALWAYS	AUTO
Detector Configuration	(0018,7005)	AREA	ALWAYS	AUTO
Detector Description	(0018,7006)	Vendor: DRC; Product: BRICK/ARRAY; Version: v1.0	ALWAYS	AUTO
Detector ID	(0018,700A)		ALWAYS	AUTO
Date of Last Detector Calibration	(0018,700C)	Same as (0018,1200)	ALWAYS	AUTO
Time of Last Detector Calibration	(0018,700E)	Same as (0018,1201)	ALWAYS	AUTO
Detector Conditions Nominal Flag	(0018,7000)	YES	ALWAYS	AUTO
Detector Temperature	(0018,7001)		ALWAYS	AUTO
Sensitivity	(0018,6000)		VNAP	AUTO
Field of View Shape	(0018,1147)	RECTANGLE	ALWAYS	AUTO
Field of View Origin	(0018,7030)		ALWAYS	AUTO
Field of View Rotation	(0018,7032)		ALWAYS	AUTO
Filed of View Horizontal Flip	(0018,7034)		ALWAYS	AUTO
Imager Pixel Spacing	(0018,1164)	.070\0.070	ALWAYS	AUTO
Date of Last Detector Calibration	(0018,700C)		ALWAYS	AUTO
Detector Active Shape	(0018,7024)	RECTANGLE	ALWAYS	AUTO
Detector Active Dimension(s)	(0018,7026)		ALWAYS	AUTO

Table 7.1-13 DX Positioning Module of Created SOP Instances

Attribute Name	Tag	Value	Presence of Value	Source
View Position	(0018,5101)	User selects view to acquire	ALWAYS	AUTO, USER
View Code Sequence	(0054,0220)	See Table 7.1-18		
Distance Source to Detector	(0018,1110)		VNAP	AUTO
Estimated Radiographic Magnification Factor	(0018,1114)	1.0 default, 1.8 for magnification views	ALWAYS	AUTO
Positioner Type	(0018,1508)	See Table 7.1-18		
Positioner Primary Angle	(0018,1510)	See Table 7.1-18		
Body Part Thickness	(0018,11A0)	From x-ray system	ALWAYS	AUTO
Compression Force	(0018,11A2)	From x-ray system	ALWAYS	AUTO

Table 7.1-14 X-ray Acquisition Dose Module of Created SOP Instances

Attribute Name	Tag	Value	Presence of Value	Source
KVP	(0018,0060)	See Table 7.1-15		
X-Ray Tube Current	(0018,1151)	See Table 7.1-15		
Exposure Time	(0018,1150)	See Table 7.1-15		
Exposure	(0018,1152)	See Table 7.1-15		
Exposure in uAs	(0018,1153)	From x-ray system	ALWAYS	AUTO
Distance Source to Detector	(0018,1110)	See Table 7.1-13		
Distance Source to Patient	(0018,1111)		VNAP	AUTO
Body Part Thickness	(0018,11A0)	See Table 7.1-13		
Entrance Dose	(0040,0302)		ALWAYS	AUTO
Entrance Dose in mGy	(0040,8302)		ALWAYS	AUTO
Half Value Layer	(0040,0314)		ALWAYS	AUTO
Organ Dose	(0040,0316)		ALWAYS	AUTO
Organ Exposed	(0040,0318)	See Table 7.1-18		
Anode Target Material	(0018,1191)	See Table 7.1-15		
Filter Material	(0018,7050)	MOLYBDENUM, RHODIUM	ALWAYS	AUTO
Filter Thickness Minimum	(0018,7052)		VNAP	AUTO
Filter Thickness Maximum	(0018,7054)		VNAP	AUTO
Relative X-Ray Exposure	(0018,1405)		ALWAYS	AUTO

Table 7.1-15 X-ray Generation Module of Created SOP Instances

Attribute Name	Tag	Value	Presence of Value	Source
KVP	(0018,0060)	From x-ray system	ALWAYS	AUTO
X-ray Tube Current	(0018,1151)	From x-ray system	ALWAYS	AUTO
Exposure Time	(0018,1150)	From x-ray system	ALWAYS	AUTO
Exposure	(0018,1152)	From x-ray system	ALWAYS	AUTO
Focal Spot	(0018,1190)		ALWAYS	AUTO
Anode Target Material	(0018,1191)	MOLYBDENUM	ALWAYS	AUTO
Exposure Control Mode	(0018,7060)	MANUAL TEC AUTO_KV AUTO_TIME AUTO_FILTER	ALWAYS	AUTO
Exposure Control Mode Description	(0018,7062)	MANUAL TEC LORAD AEC SENSOR POSITION x LORAD AUTO AEC	ALWAYS	AUTO
Exposure Status	(0018,7064)	NORMAL	ALWAYS	AUTO

Table 7.1-16 X-ray Filtration Module of Created SOP Instances

Attribute Name	Tag	Value	Presence of Value	Source
The supported attributes are listed in the X-ray Acquisition Dose module. See Table 7.1-14.				

Table 7.1-17 X-ray Grid Module of Created SOP Instances

Attribute Name	Tag	Value	Presence of Value	Source
Grid	(0018,1166)	HTC_IN, HTC_OUT	ALWAYS	AUTO
Grid Period	(0018,7048)		VNAP	AUTO

Table 7.1-18 Mammography Image Module of Created SOP Instances

Attribute Name	Tag	Value	Presence of Value	Source
Positioner Type	(0018,1508)	MAMMOGRAPHIC	ALWAYS	AUTO
Positioner Primary Angle	(0018,1510)		ALWAYS	AUTO
Positioner Secondary Angle	(0018,1511)		VNAP	AUTO
Image Laterality	(0020,0062)	R, L	ALWAYS	AUTO, USER
Organ Exposed	(0040,0318)	BREAST	ALWAYS	AUTO
Implant Present	(0028,1300)	YES, NO	ALWAYS	AUTO
Partial View	(0028,1350)		VNAP	AUTO
Partial View Description	(0028,1351)		VNAP	AUTO
Anatomic Region Sequence	(0008,2218)		ALWAYS	AUTO
> Code Value	(0008,0100)	T-04000		
> Code Scheme Designator	(0008,0102)	SNM3		
> Code Meaning	(0008,0104)	Breast		
View Code Sequence	(0054,0220)	One from CID 4014: CC, MLO, LM, ML, LMO, SIO, FB, XCCL, XCCM, Specimen	ALWAYS	AUTO, USER
> Code Value	(0008,0100)			
> Code Scheme Designator	(0008,0102)			
> Code Meaning	(0008,0104)			
>View Modifier Code Sequence	(0054,0222)	Zero or more from CID 4015: M, S, RL, RM, CV, AT, TAN, ID (M)agnification and/or (S)pot compression is based on the compression paddle	VNAP	AUTO, USER
>> Code Value	(0008,0100)			
>> Code Scheme Designator	(0008,0102)			
>> Code Meaning	(0008,0104)			

Table 7.1-19 Acquisition Context Module of Created SOP Instances

Attribute Name	Tag	Value	Presence of Value	Source
Acquisition Context Sequence	(0040,0555)		EMPTY	AUTO

Table 7.1-20 SOP Common Module of Created SOP Instances

Attribute Name	Tag	Value	Presence of Value	Source
SOP Class UID	(0008,0016)	UID for Digital Mammography X-ray Image Storage – For Presentation or For Processing	ALWAYS	AUTO
SOP Instance UID	(0008,0018)	Unique value generated by AWS	ALWAYS	AUTO
Specific Character Set	(0008,0005)	ISO_IR 100	ALWAYS	AUTO
Instance Number	(0020,0013)	See Table 7.1-8		

7.1.2 Usage of Attributes from Received IODs

The following attributes are required to be present with a non-zero length value for successful interpretation of received Image SOP Instances:

- (0008,0016) SOP Class UID: one of the supported values
- (0008,0068) Presentation Intent Type
- (0008,1030) Study Description
- (0010,0020) Patient ID
- (0020,0011) Series Number
- (0020,0013) Instance Number
- (0028,0010) Rows
- (0028,0011) Columns
- At least one of the following:
 - (0008,0050) Accession Number
 - (0020,0010) Study ID
 - (0040,1001) Requested Procedure ID
- At least one attribute that identifies the mammography view
- Group (0019) LORAD Selenia Private Attributes

7.1.3 Attribute Mapping

The default relationships between attributes received via Modality Worklist and stored in acquired images and MPPS Instances are summarized in Table 7.1-21. Attribute mapping is configurable.

Table 7.1-21 Attribute Mapping between Modality Worklist, Image, and MPPS

Modality Worklist	Image IOD	MPPS
Patient's Name	Patient's Name	Patient's Name
Patient ID	Patient ID	Patient ID
Patient's Birth Date	Patient's Birth Date	Patient's Birth Date
Patient's Birth Time	Patient's Birth Time	
Patient's Sex	Patient's Sex	Patient's Sex
Other Patient IDs	Other Patient IDs	
Patient Comments	Patient Comments	
Admitting Diagnoses Description	Admitting Diagnoses Description	
Referring Physician's Name	Referring Physician's Name	
Study Description	Study Description	
Study ID	Study ID	Study ID
Additional Patient History	Additional Patient History	
Physician(s) of Record	Physician(s) of Record	
Name of Physician(s) reading study	Name of Physician(s) reading study	
		Scheduled Step Attributes Sequence
Referenced Study Sequence	Referenced Study Sequence	>Referenced Study Sequence
>Referenced SOP Class UID	>Referenced SOP Class UID	>>Referenced SOP Class UID
>Referenced SOP Instance UID	>Referenced SOP Instance UID	>>Referenced SOP Instance UID
Study Instance UID	Study Instance UID	>Study Instance UID
Accession Number	Accession Number	>Accession Number
Scheduled Procedure Step	Request Attributes Sequence	

Modality Worklist	Image IOD	MPPS
Sequence		
>Scheduled Procedure Step Description	>Scheduled Procedure Step Description	>Scheduled Procedure Step Description
>Scheduled Protocol Code Sequence	>Scheduled Protocol Code Sequence	>Scheduled Protocol Code Sequence
>>Code Value	>>Code Value	>>Code Value
>>Coding Scheme Designator	>>Coding Scheme Designator	>>Coding Scheme Designator
>>Code Meaning	>>Code Meaning	>>Code Meaning
>Scheduled Procedure Step ID	>Scheduled Procedure Step ID	>Scheduled Procedure Step ID
Requested Procedure ID	>Requested Procedure ID	>Requested Procedure ID
Requested Procedure Description	>Requested Procedure Description (Note: Standard Extended)	>Requested Procedure Description
	Performed Protocol Code Sequence	Performed Protocol Code Sequence
	>Code Value	>Code Value
	>Coding Scheme Designator	>Coding Scheme Designator
	>Code Meaning	>Code Meaning
	Performed Procedure Step ID	Performed Procedure Step ID
	Performed Procedure Step Start Date	Performed Procedure Step Start Date
	Performed Procedure Step Start Time	Performed Procedure Step Start Time
	Performed Procedure Step Description	Performed Procedure Step Description
Scheduled Protocol Code Sequence	Procedure Code Sequence	Procedure Code Sequence
		Performed Series Sequence
	Protocol Name	>Protocol Name

The following additional rules apply for mapping Modality Worklist attributes to image and MPPS Instances:

(0040,0007) Scheduled Procedure Step Description, (0040,0008) Scheduled Protocol Code Sequence, (0040,0009) Scheduled Procedure Step ID, (0040,1001) Requested Procedure ID:

- For a scheduled procedure the Acquisition Workstation incorporates these attributes from the worklist into the Request Attributes Sequence (0040,0275) of the image object and the Scheduled Step Attributes Sequence (0040,0270) of the MPPS Instance.
- For unscheduled procedures there is no Request Attributes Sequence (0040,0275) in the image object, and these attributes are absent from the MPPS Instance.

(0020,000D) Study Instance UID:

- For a scheduled procedure the Acquisition Workstation copies this attribute from the worklist into the image object and the Scheduled Step Attributes Sequence (0040,0270) of the MPPS Instance.
- For unscheduled procedures the Acquisition Workstation creates the value.

(0008,1110) Referenced Study Sequence:

- For a scheduled procedure the Acquisition Workstation incorporates this attribute from the worklist into the image object and the Scheduled Step Attributes Sequence (0040,0270) of the MPPS Instance. The number of sequence items corresponds to the number of scheduled procedure steps grouped for a performed procedure step (normally one).
- For unscheduled procedures there is no Referenced Study Sequence in the image object or the MPPS Instance.

(0008,0050) Accession Number:

- For a scheduled procedure the Acquisition Workstation incorporates this attribute from the worklist into the image object and the Scheduled Step Attributes Sequence (0040,0270) of the MPPS Instance.

7.1.4 Coerced/Modified Attributes

The Acquisition Workstation can be configured to add, edit, or remove specific attributes in received SOP Instances. By default, the Acquisition Workstation will attempt to add missing attributes that are required for interpretation by the display module, such as the Private Attributes (0019).

The following characters in textual return key attribute values of a Modality Worklist item are modified automatically by the Acquisition Workstation when mapped to an image object:

- Ampersand Symbol (&): Mapped to “.AND.”
- Double Quote Symbol (“): Mapped to “” (single quote)
- Greater Than Symbol (>): Mapped to “.GT.”
- Less Than Symbol (<): Mapped to “.LT.”

7.2. Data Dictionary of Private Attributes

Created SOP Instances may contain a Private Group (0011) labeled HIPAA Private Creator, containing encrypted patient attributes.

Created SOP Instances may contain a Private Group (0019) labeled LORAD Selenia, containing proprietary image characteristics relating to compression paddle, collimation, and automatic exposure control.

7.3. Coded Terminology and Templates

7.4. Grayscale Image Consistency

7.5. Standard Extended/Specialized/Private SOP Classes

By default, Digital Mammography X-Ray Image Storage – For Processing and Digital Mammography X-Ray Image Storage – For Presentation SOP Classes are Standard Extended by the attributes defined in Table 7.5-1. The attributes contained in created SOP Instances are configurable.

Table 7.5-1 Standard Extended Attributes of Created SOP Instances

Attribute Name	Tag	Value	Presence of Value	Source
Modalities in Study	(0008,0061)		VNAP	AUTO
Medical Record Locator	(0010,1090)		VNAP	AUTO
Laterality	(0020,0060)		EMPTY	AUTO
Other Study Numbers	(0020,1070)		VNAP	AUTO
Pixel Spacing	(0028,0030)	Depends on magnification factor	ALWAYS	AUTO
Study Status ID	(0030,000A)		ALWAYS	AUTO
Study Priority ID	(0032,000C)		ALWAYS	AUTO
Scheduled Study Start Date	(0032,1000)		VNAP	AUTO
Scheduled Study Start Time	(0032,1001)		VNAP	AUTO
Reason For Study	(0032,1030)	SCREENING	ALWAYS	AUTO
Requesting Physician	(0032,1032)		VNAP	AUTO
Requested Procedure Description	(0032,1060)		ALWAYS	AUTO

Attribute Name	Tag	Value	Presence of Value	Source
Study Comments	(0032,4000)		VNAP	AUTO
Admission ID	(0038,0010)		ALWAYS	AUTO
Route of Admission	(0038,0016)		VNAP	AUTO
Admitting Date	(0038,0020)		VNAP	AUTO
Admitting Time	(0038,0021)		VNAP	AUTO
Patient Location	(0038,0300)		VNAP	AUTO
Performed Procedure Step Status	(0040,0252)		VNAP	AUTO
Requested Procedure ID	(0040,1001)		ANAP	AUTO
Requested Procedure Priority	(0040,1003)		VNAP	AUTO
Patient Transport Arrangements	(0040,1004)		VNAP	AUTO
Names of Intended Recipients of Results	(0040,1010)		VNAP	AUTO

7.6. Private Transfer Syntaxes

None.

8.0 Selenia DICOM Services When Using Digital StereoLoc II Option

8.1. Overview

The Hologic Selenia Acquisition Workstation with the Selenia Digital StereoLoc II option allows stereotactic images to be acquired on the Selenia Acquisition workstation, which then sends the images directly to a Selenia Digital StereoLoc II workstation. When in stereoloc mode the only DICOM service used by the Selenia Acquisition Workstation is Modality Worklist. See section 3.2.1 Modality Worklist Client AE in this document for information pertaining to the Selenia Acquisition Workstation conformance to DICOM Modality Worklist.

The Selenia Digital StereoLoc II workstation is used to execute all other DICOM services. Refer to the Selenia Digital StereoLoc II DICOM Conformance Statement for information regarding its use of DICOM services.