



Digital Radiography System

CXDI-40G

COMPACT

EXPANDING THE BENEFITS OF DIGITAL RADIOGRAPHY

■ **Upgrading to Digital Radiography with Ease**

The CXDI-40G COMPACT is equipped with the large image sensor and high-quality capabilities of the CXDI-40EG but in minimal housing. This unit can be retrofitted into a range of radiography devices – upright stands, RF tables, Bucky units – so easy installation is possible into widely-used Bucky units of existing facilities. Upgrade your current equipment with CXDI-40G COMPACT and greatly streamline radiographic workflow.

■ **Extensive Radiographic Applications**

The CXDI-40G COMPACT by Canon is a 43 cm x 43 cm (17" x 17") digital radiography sensor that provides superior-quality diagnostic image previews mere seconds after exposure. With its multiple applications, efficiently capture high-resolution radiological images in a timely manner to meet your institution's general radiographic needs.



The sleek and compact CXDI-40G COMPACT allows for easy upgrades to your existing radiography equipment, and fits easily into most universal Bucky systems.

System Configuration Examples

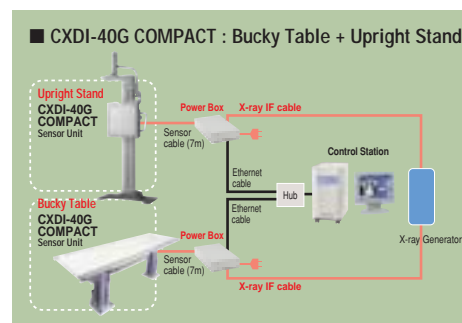
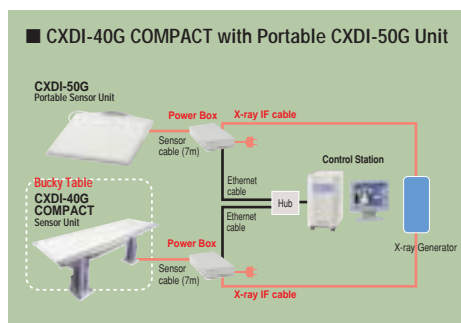
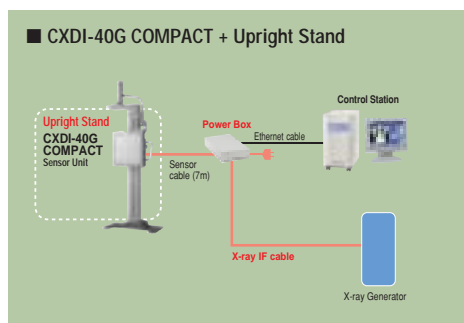

For exact system configuration details, please contact your local authorized Canon representative.

CXDI-40G COMPACT Specifications

Purpose	General radiography
Method	Flat panel detector: scintillator & amorphous silicon (a-Si)
Scintillator	GOS (Gd ₂ O ₂ S:Tb)
Pixel pitch	160 x 160 microns
Pixels	2,688 x 2,688 pixels (7.2 million pixels)
Image size	Automatic sizing up to 17 x 17 in. (43 x 43 cm)
A/D	14-bit
Grayscale	4,096 grayscale (12-bit)
Preview image access time*	Approx. 3 – 5 seconds after X-ray exposure
Interface	DICOM 3.0, 10BASE-T/100BASE-TX/1000BASE-T Ethernet
DICOM	DICOM 3.0 compatible, Print Management Service Class (SCU), Storage Service Class (SCU), and others
Voltage	100V-120V AC (50/60Hz), 200V-240V AC (50/60Hz)
Power consumption	Sensor unit: 200VA maximum
Operating environment	Sensor unit: 50 – 95°F (10 – 35°C), 30 – 75% RH (non-condensing)
Dimensions (W x L x H)	21.4 x 18.5 x 1.3 in. (543 x 470 x 32 mm)
Weight	Sensor unit: 24 lb. (11 kg), without cable

*Actual times may differ due to various factors.

■ User Options

Grid	Please contact your local authorized Canon representative.
Software options	Please contact your local authorized Canon representative.

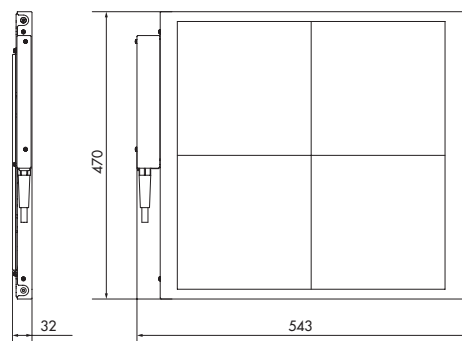

Please inquire to your local authorized Canon representative whether installation is possible.

Specifications are subject to change without notice.

Names of companies or products appearing in this document are trademarks and/or registered trademarks of their respective owners.

Canon CANON INC.
MEDICAL EQUIPMENT GROUP

30-2, Shimomaruko, 3-chome, Ohta-ku, Tokyo 146-8501, Japan
Telephone: (03)3757-8526 FAX: (03)5482-3960

CANON MEDICAL SYSTEMS

a division of Canon U.S.A., Inc.
15955 Alton Parkway, Irvine, CA 92618-3731, U.S.A.
Telephone: (800) 970-7227, (949) 753-4160 Fax: (949) 753-4164
<http://www.usa.canon.com/DR>

CANON EUROPA N.V. MEDICAL SYSTEMS DIVISION

Bovenkerkerweg 59-61, P.O. Box 2262, 1185 XB Amstelveen, The Netherlands
Telephone: (020) 545-8926 Fax: (020) 545-8220
<http://medical.canon-europe.com/>